

OUTER ROTOR DOUBLE INLET DIRECT DRIVE CENTRIFUGAL FANS

Characteristics

- Appropriately used in the following devices:
 - Air transport system for heat exchangers and range hood
 - Cooling system for electronic and communication equipment
- For ease of handling and installation, miniaturization and light-weight of the fan achieved through integrated design of structure
- Quality ensured by acquisition of CE mark (i.e. European Conformity), which literally means that the product complies with the essential requirements of the relevant European health, safety and environmental legislation
- Regardless of frequency, speed control possible
- Excellent product reliability ensured by illumination process
- Excellent energy rating achieved due to low electricity consumption (high efficiency) relative to air volume
- Appropriate for high air volume



Product data

MODEL	Static Pressure		Air Volume	Page
	Pa	mmAq	m ³ /min	
AOS2D-120-126A	392	40	6.0	121p
AOS2D-133-150A	588	60	13.3	
AOS4D-133-200A	225	23	7.5	122p
AOS2D-145-150A-1	568	58	8.2	
AOS2D-145-150A-2	529	54	11.0	123p
AOS4D-145-200A	176	18	11.5	
AOS2D-160-160A	764	78	16.0	124p
AOS4D-160-200A	255	26	23.5	
AOS4D-180-180A	314	32	28.0	125p

• AOS2D-120-126A

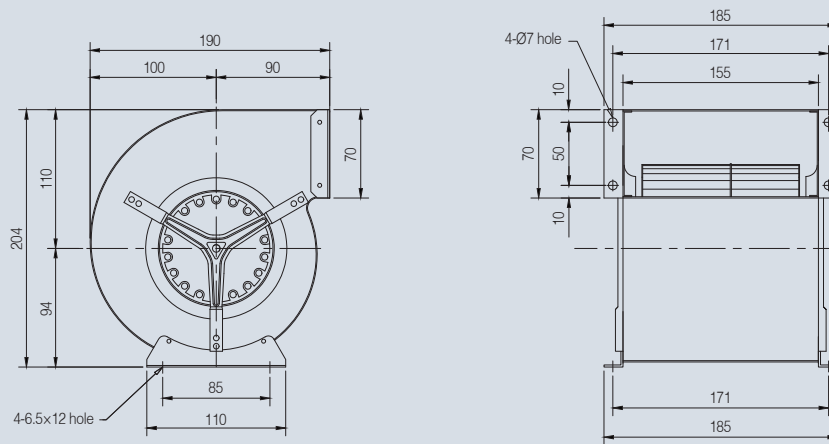

Power source			Static Pressure Pa	Air Volume m³/min	Input power W	Current A	Rotative speed RPM
Phase	V	Hz					
∅ 1	220	60Hz	1.6	212	110	0.5	1600
∅ 1	220	50Hz	1.2	247	100	0.6	1650

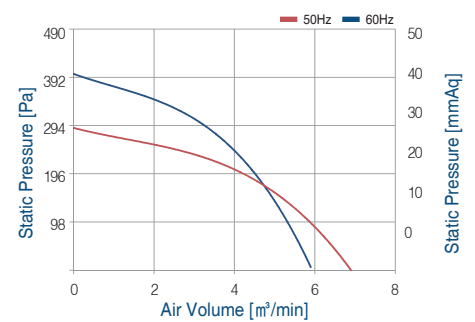

• AOS2D-133-150A

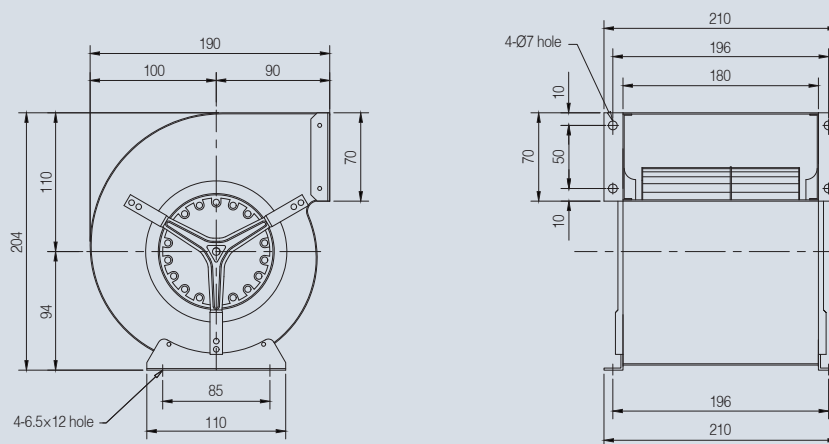

Power source			Static Pressure Pa	Air Volume m³/min	Input power W	Current A	Rotative speed RPM
Phase	V	Hz					
∅ 1	220	60Hz	588	13.3	190	0.9	2100
∅ 1	220	50Hz	392	11.7	180	0.8	1700

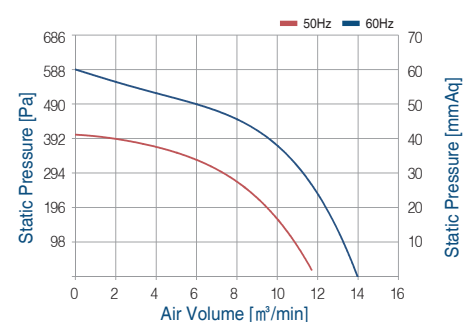

DOUBLE INLET DIRECT DRIVE CENTRIFUGAL FANS

• AOS4D-133-200A

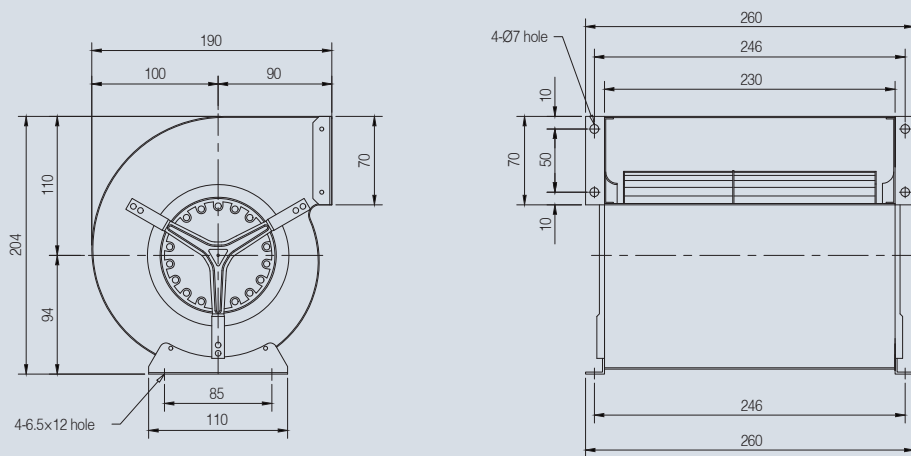

Power source			Static Pressure Pa	Air Volume m³/min	Input power W	Current A	Rotative speed RPM
Phase	V	Hz					
∅ 1	220	60Hz	225	7.5	80	0.4	1400
∅ 1	220	50Hz	157	7	70	0.4	1300

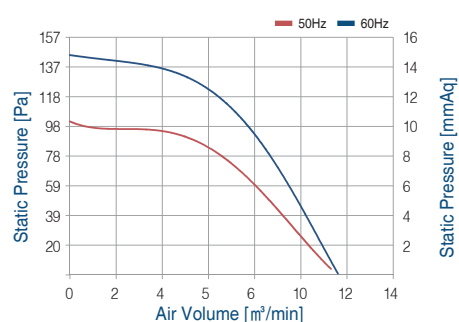

• AOS2D-145-150A-1

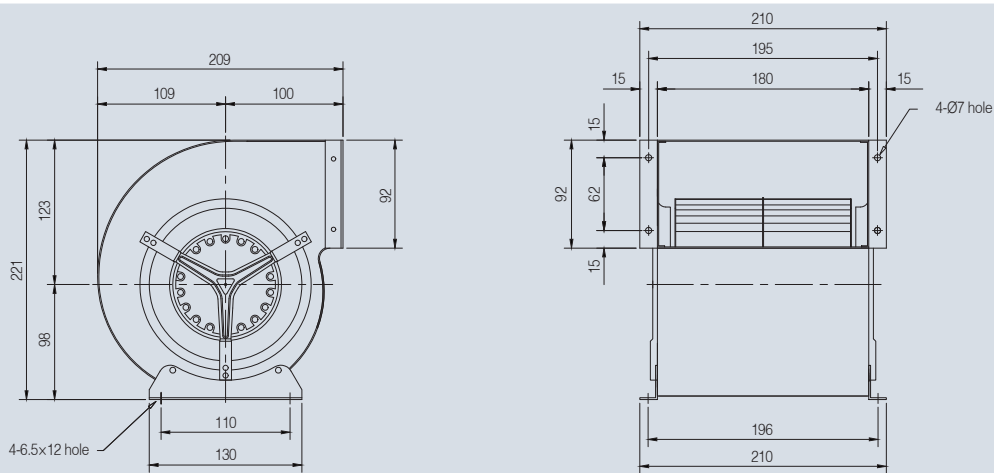

Power source			Static Pressure Pa	Air Volume m³/min	Input power W	Current A	Rotative speed RPM
Phase	V	Hz					
∅ 1	220	60Hz	568	8.2	207	1	2900
∅ 1	220	50Hz	180	9.5	189	0.9	2700

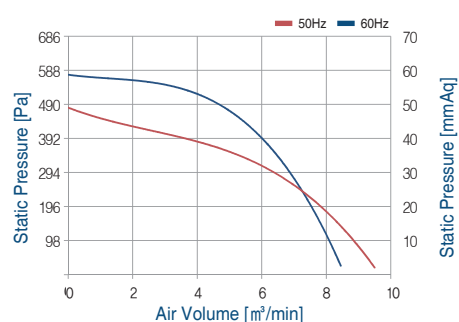

• AOS2D-145-150A-2

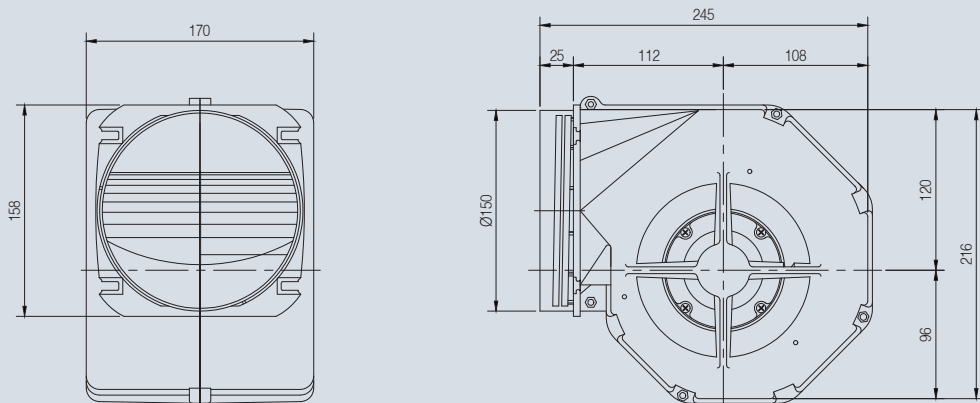

Power source			Static Pressure Pa	Air Volume m ³ /min	Input power W	Current A	Rotative speed RPM
Phase	V	Hz					
φ 1	220	60Hz	529	11	200	0.9	1450
φ 1	220	50Hz	441	9	190	0.8	1200

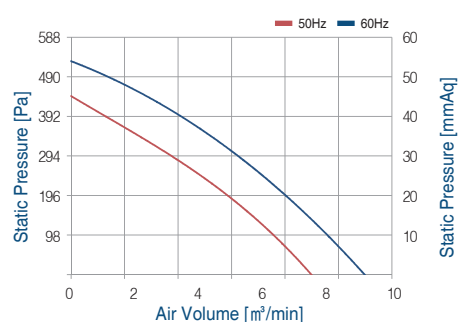

DOUBLE INLET DIRECT DRIVE CENTRIFUGAL FANS

• AOS4D-145-200A

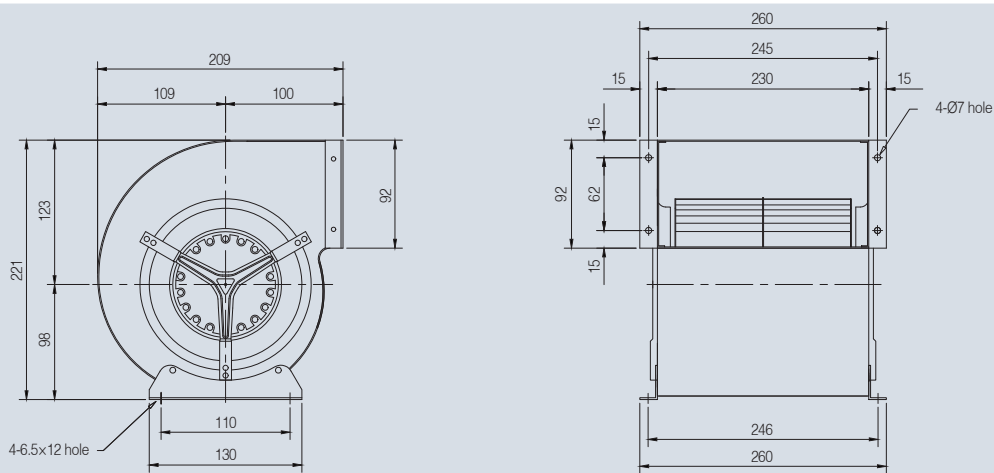

Power source			Static Pressure Pa	Air Volume m ³ /min	Input power W	Current A	Rotative speed RPM
Phase	V	Hz					
φ 1	220	60Hz	176	11.5	90	0.5	910
φ 1	220	50Hz	142	12	80	0.4	980

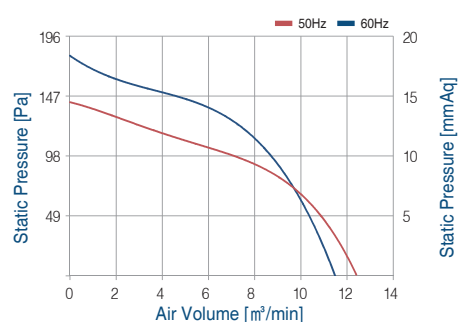

• AOS2D-160-160A

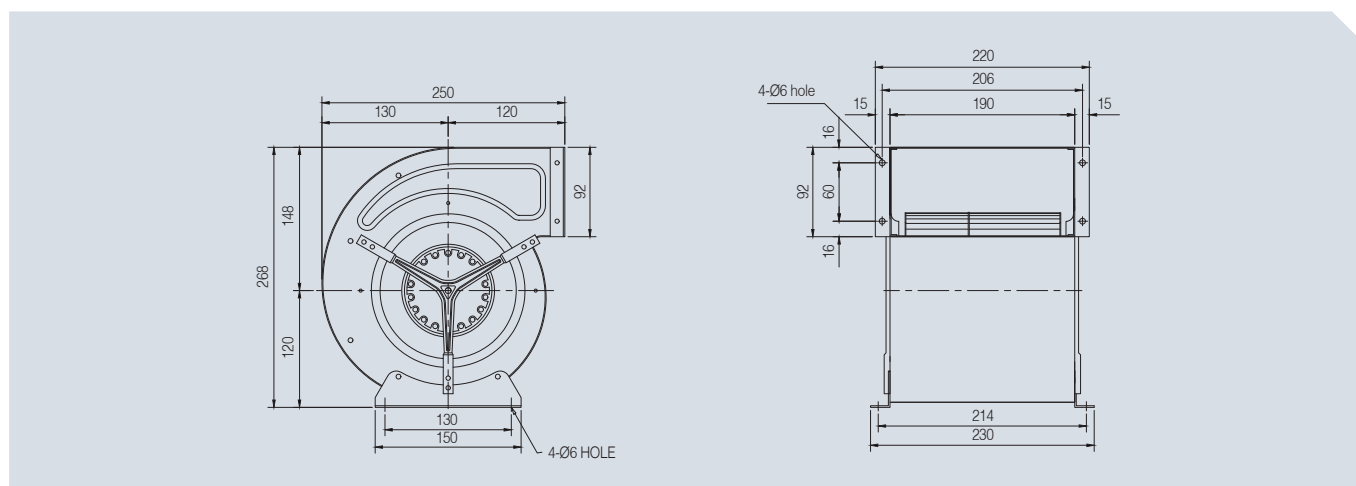

Power source			Static Pressure Pa	Air Volume m ³ /min	Input power W	Current A	Rotative speed RPM
Phase	V	Hz					
∅ 1	220	60Hz	764	16	290	1.4	1400
∅ 1	220	50Hz	637	14	260	1.3	1500

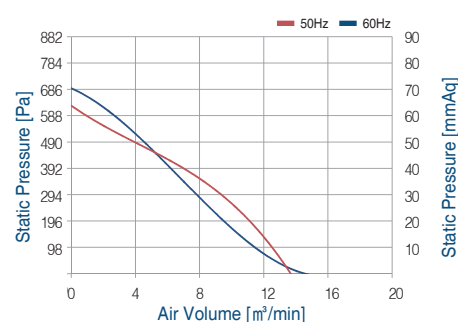

• AOS4D-160-200A

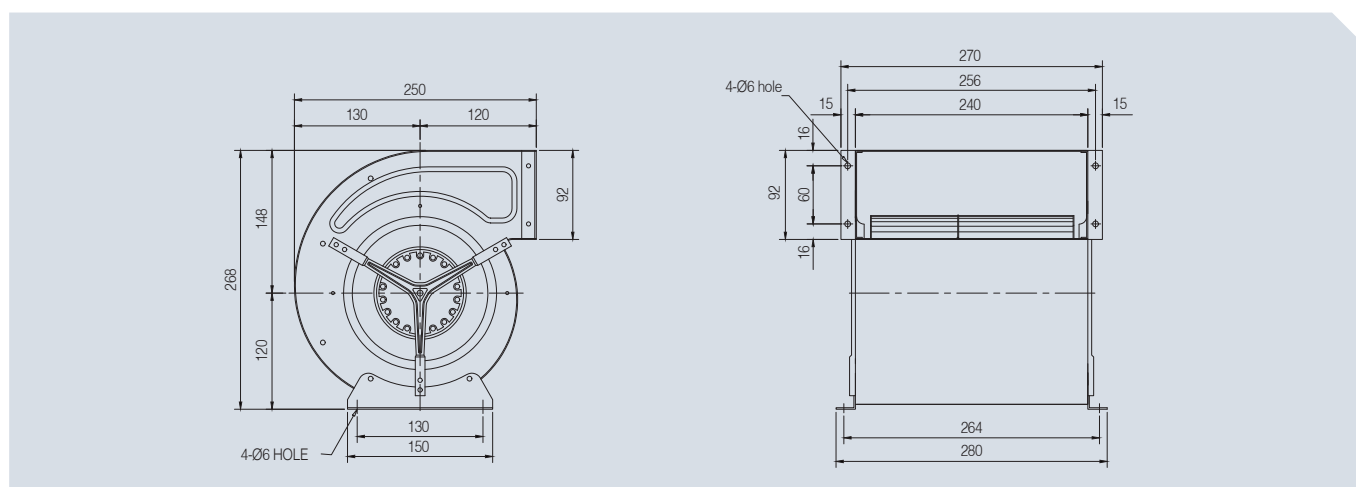

Power source			Static Pressure Pa	Air Volume m ³ /min	Input power W	Current A	Rotative speed RPM
Phase	V	Hz					
∅ 1	220	60Hz	255	23.5	280	1.2	1470
∅ 1	220	50Hz	186	21.6	190	0.9	1370

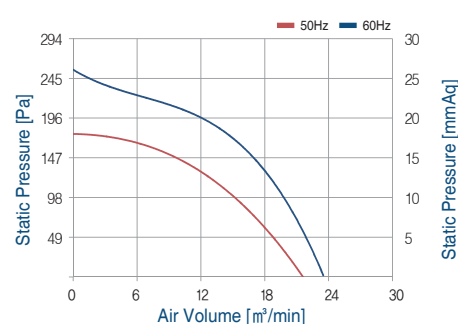

• AOS4D-180-180A

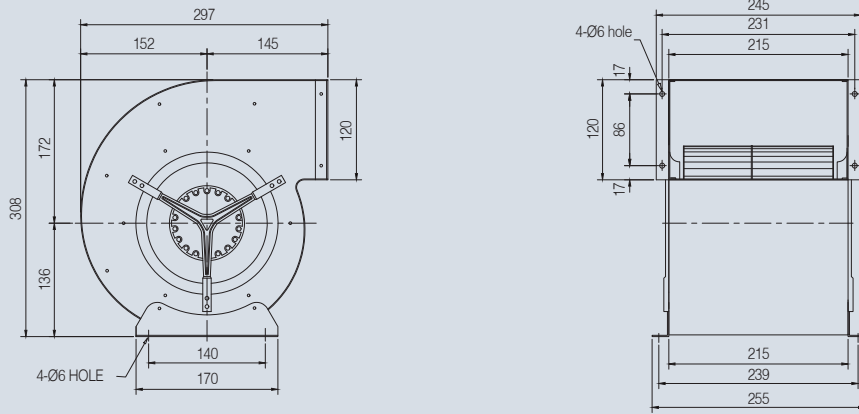

Power source			Static Pressure Pa	Air Volume m ³ /min	Input power W	Current A	Rotative speed RPM
Phase	V	Hz					
φ 1	220	60Hz	314	28	260	1.5	1300
φ 1	220	50Hz	225	26	220	1.0	1250

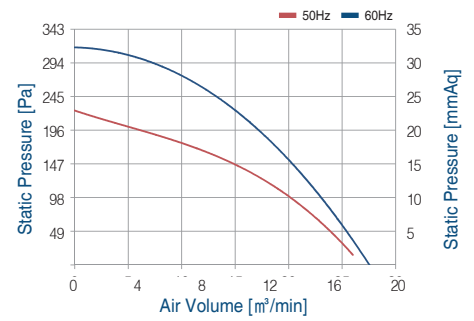

DOUBLE INLET DIRECT
DRIVE CENTRIFUGAL FANS