

# DOUBLE INLET TWIN FANS

## Characteristics

- With the adoption of biaxial direct drive system, handling and installation made easier
- Product efficiency maximized through implementation of twin structure fans (1 motor + 2 fans)
- High airflow and low noise realized relative to the area of installation
- Direction of the discharge adjustable in accordance to customer's request



## Product data

MODEL	Motor Power		Static Pressure		Air Volume	Page
	kw	HP	Pa	mmAq	m <sup>3</sup> /min	
AT-060-040	0.11	1/4	196	20	32	81p
AT-070-040	0.36	1/2	274	28	53	
AT-080-040	0.67	1	402	41	75	82p
AT-090-040	1.25	1.5	490	50	92	
AT-010-060	1.1	1.5	206	21	143	83p
AT-010-080	0.75	1	392	40	103	
AT-012-060	2.2	3	294	30	200	84p
AT-012-080	1.1	1.5	549	56	146	
AT-013-060	3.7	5	627	64	280	85p
AT-013-080	2.2	3	353	36	210	
AT-015-080	5.5	7.5	519	53	416	86p

• AT-060-040

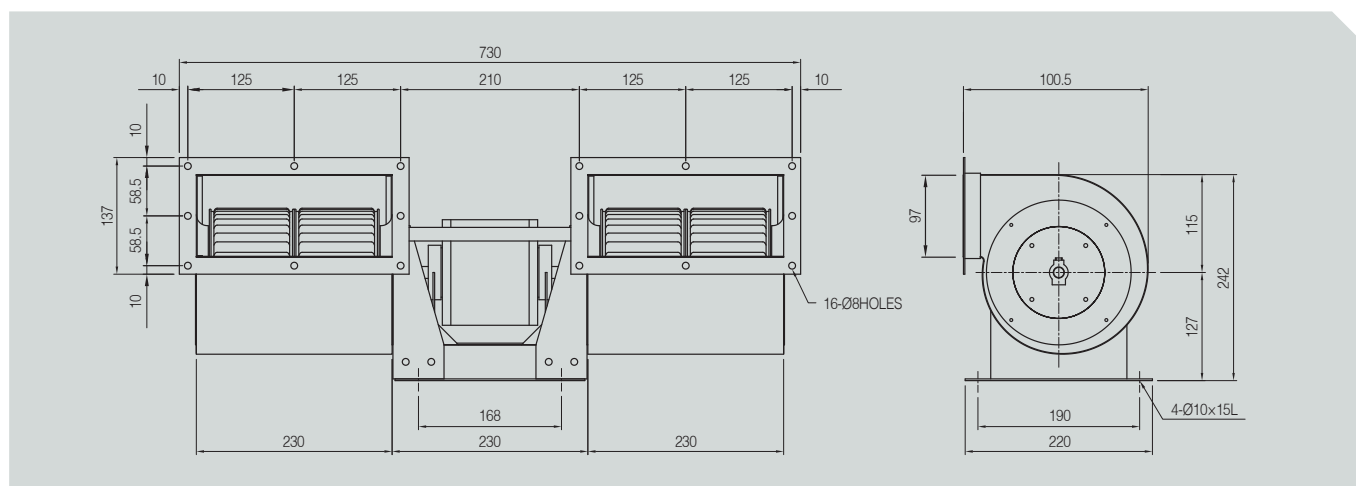

Power source			Static Pressure Pa	Air Volume CMM	Motor power W	Input power W	Current A	Rotative speed RPM
Phase	V	Hz						
∅ 1	220	60Hz	196	32	110	240	1.5	1650
∅ 1	220	50Hz	137	32	110	200	1.2	1350

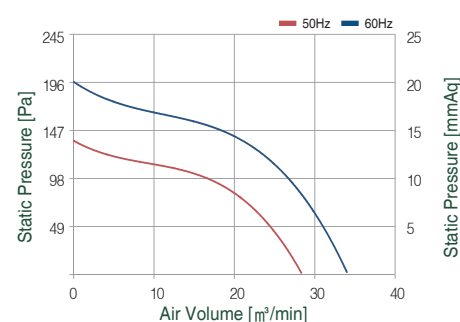

• AT-070-040

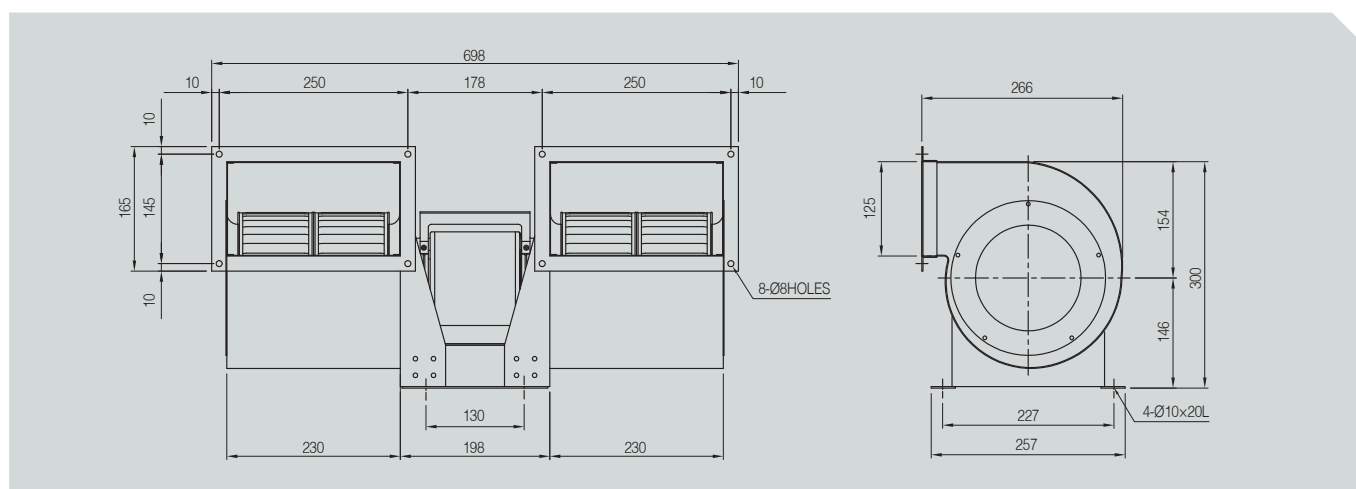

Power source			Static Pressure Pa	Air Volume CMM	Motor power W	Input power W	Current A	Rotative speed RPM
Phase	V	Hz						
∅ 1	220	60Hz	274	53	360	550	1.9	1650
∅ 3	380							
∅ 1	220	50Hz	191	44	210	320	1.1	1370
∅ 3	380							

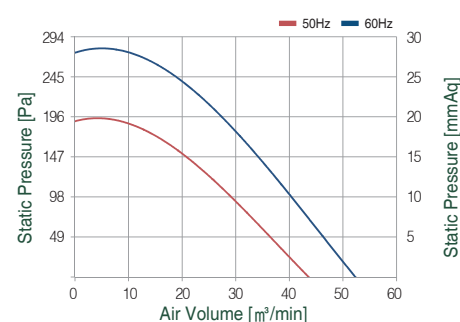

DOUBLE INLET TWIN FANS

• AT-080-040

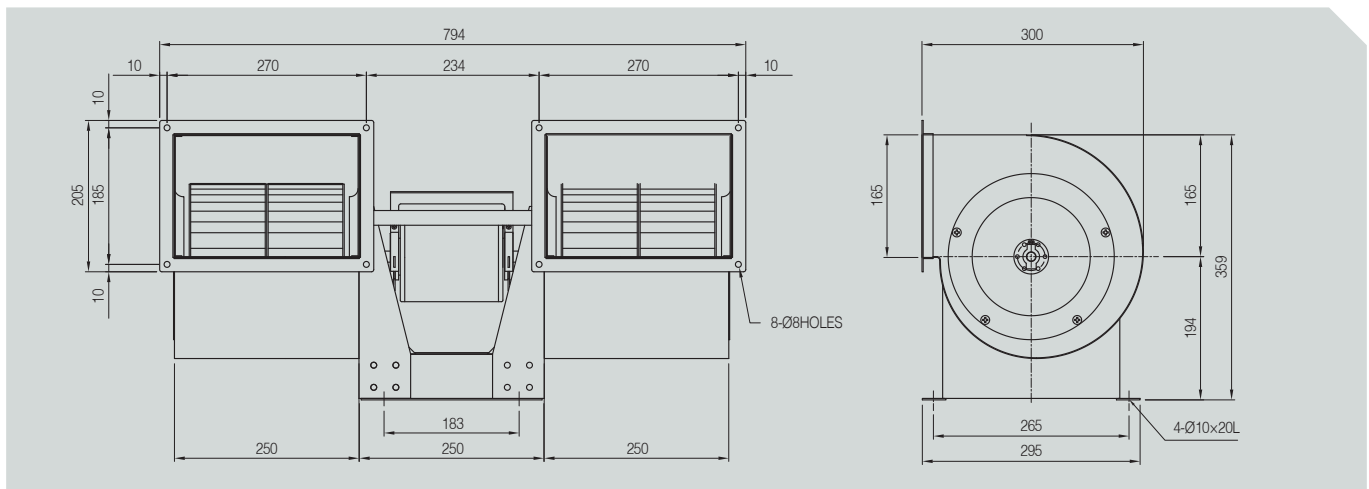

Power source			Static Pressure Pa	Air Volume CMM	Motor power W	Input power W	Current A	Rotative speed RPM
Phase	V	Hz						
∅ 1	220	60Hz	402	75	670	850	2.6	1650
∅ 3	380							
∅ 1	220	50Hz	279	62	390	500	1.5	1370
∅ 3	380							

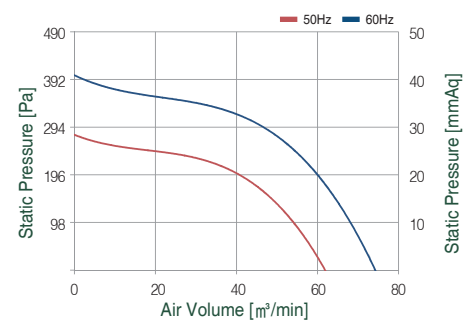

• AT-090-040

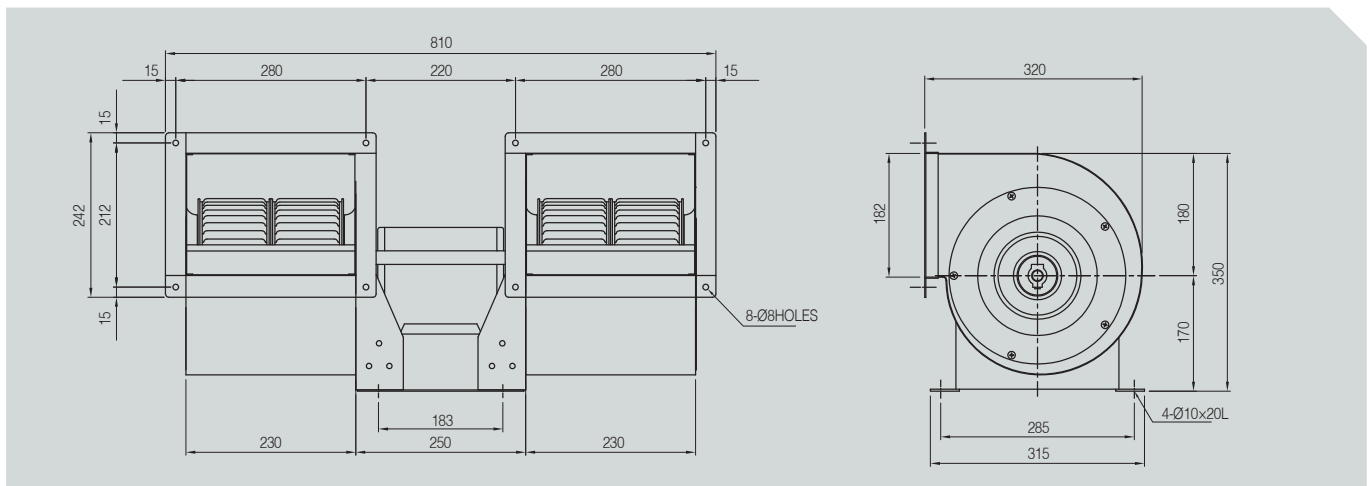

Power source			Static Pressure Pa	Air Volume CMM	Motor power W	Input power W	Current A	Rotative speed RPM
Phase	V	Hz						
∅ 1	220	60Hz	490	92	1250	2300	11	1650
∅ 3	380							
∅ 1	220	50Hz	333	76	720	1330	6.4	1370
∅ 3	380							

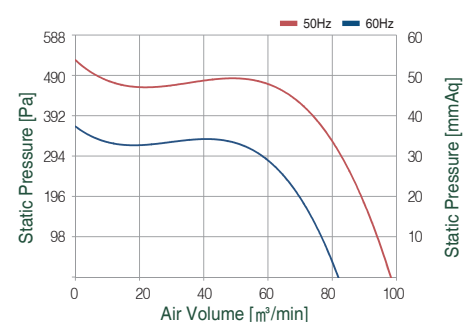

• AT-010-060

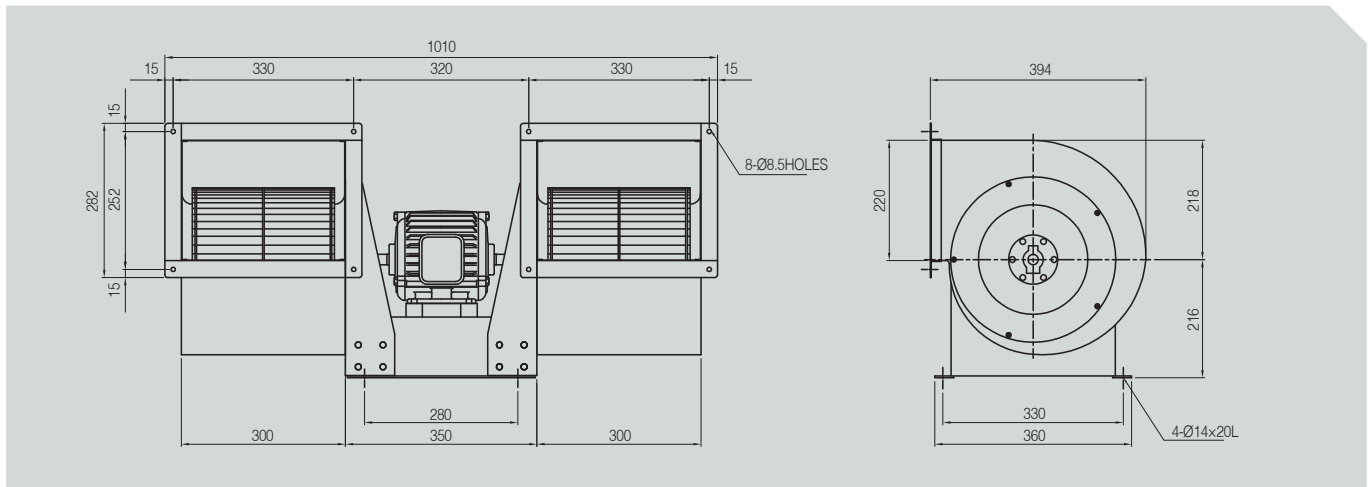

Power source			Static Pressure Pa	Air Volume CMM	Motor power W	Input power W	Current A	Rotative speed RPM
Phase	V	Hz						
φ 1 φ 3	220	60Hz	392	143	1100	2030	6.8	1150
	380							
φ 1 φ 3	220	50Hz	255	115	920	1690	5.5	1690
	380							

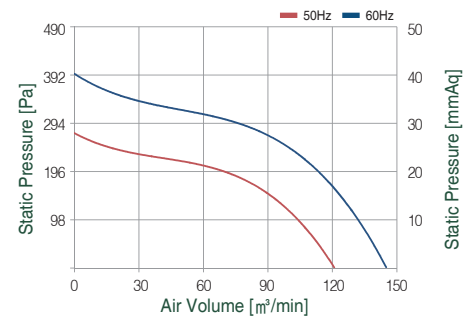

• AT-010-080

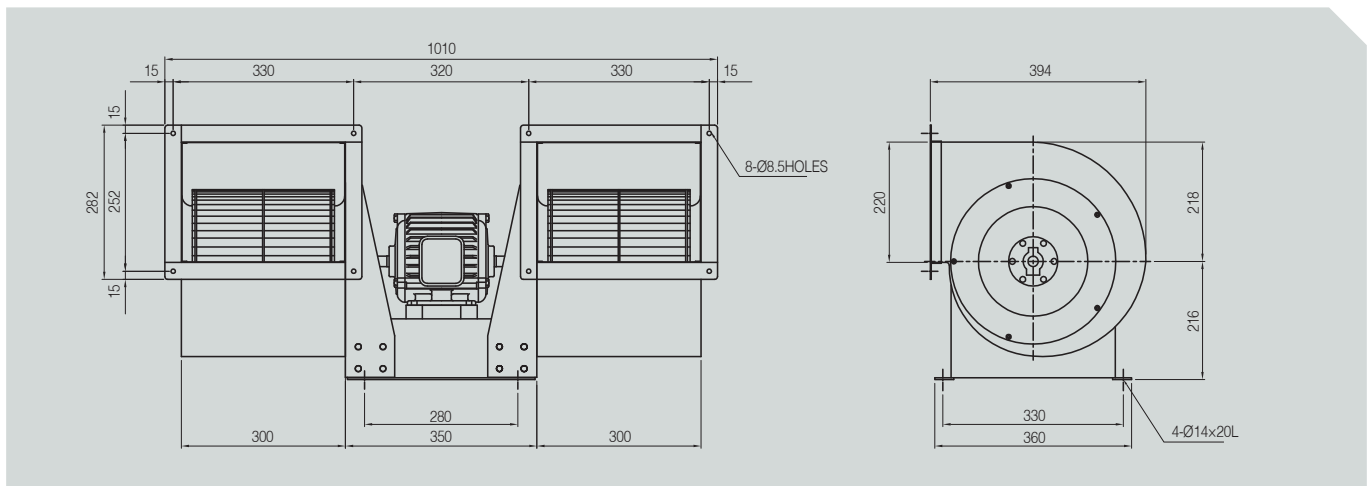

Power source			Static Pressure Pa	Air Volume CMM	Motor power W	Input power W	Current A	Rotative speed RPM
Phase	V	Hz						
φ 1 φ 3	220	60Hz	206	103	750	1300	3.5	850
	380							
φ 1 φ 3	220	50Hz	137	83	630	1080	2.8	700
	380							

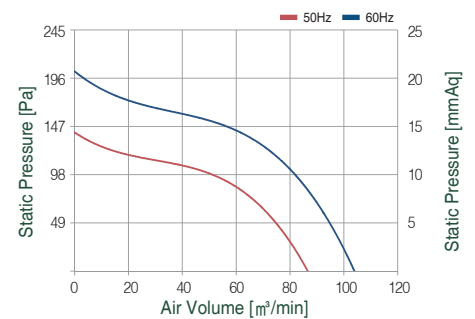

DOUBLE INLET TWIN FANS

• AT-012-060

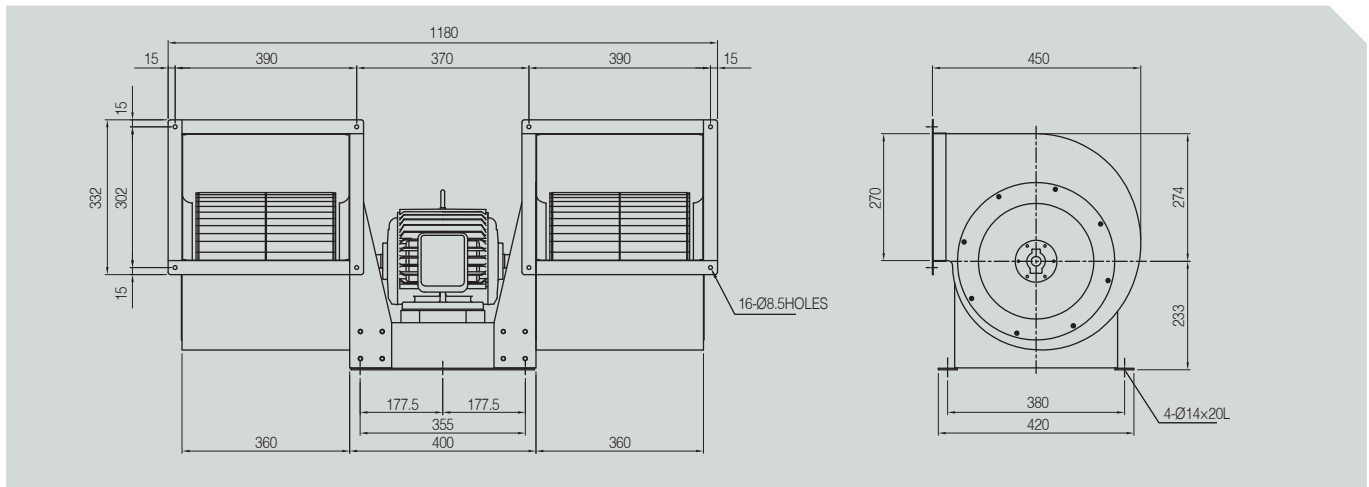

Power source			Static Pressure Pa	Air Volume CMM	Motor power W	Input power W	Current A	Rotative speed RPM
Phase	V	Hz						
∅ 3	220	60Hz	549	200	2200	3800	9.5	1150
	380							
∅ 3	220	50Hz	353	160	1840	3160	7.6	920
	380							

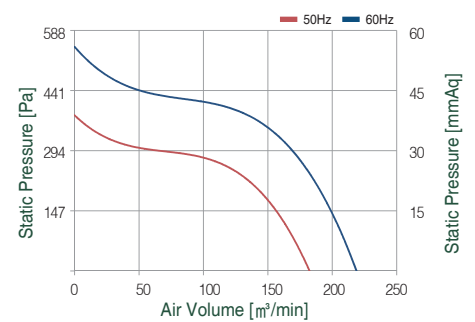

• AT-012-080

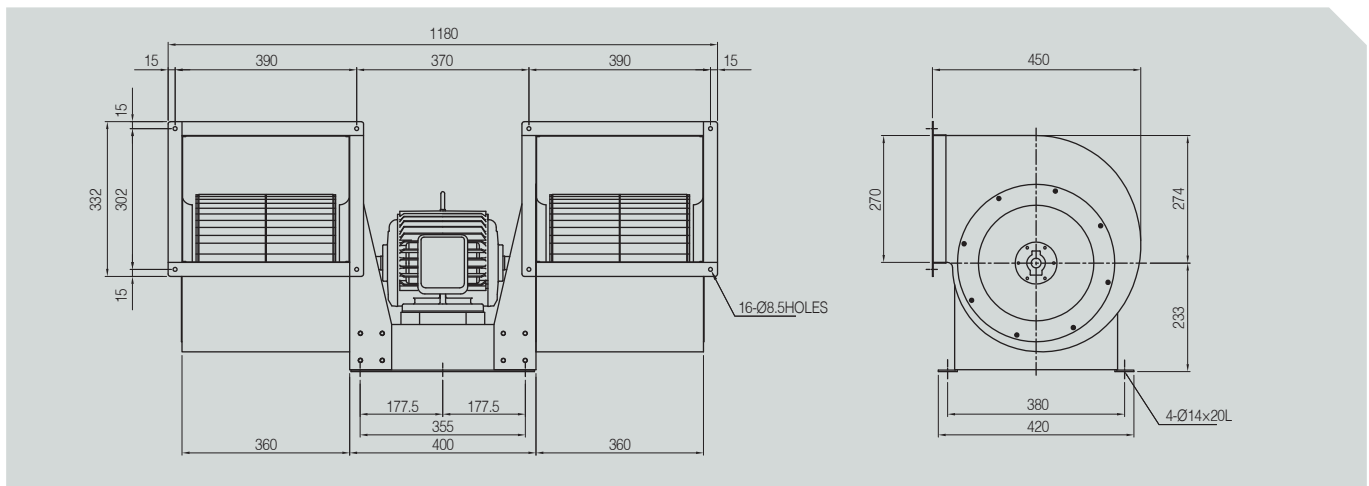

Power source			Static Pressure Pa	Air Volume CMM	Motor power W	Input power W	Current A	Rotative speed RPM
Phase	V	Hz						
∅ 3	220	60Hz	294	146	1100	2010	6.6	850
	380							
∅ 3	220	50Hz	196	117	920	1670	5.3	700
	380							

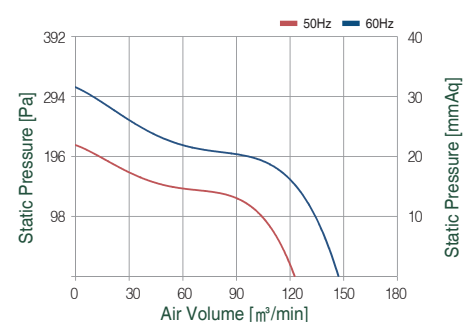

• AT-013-060

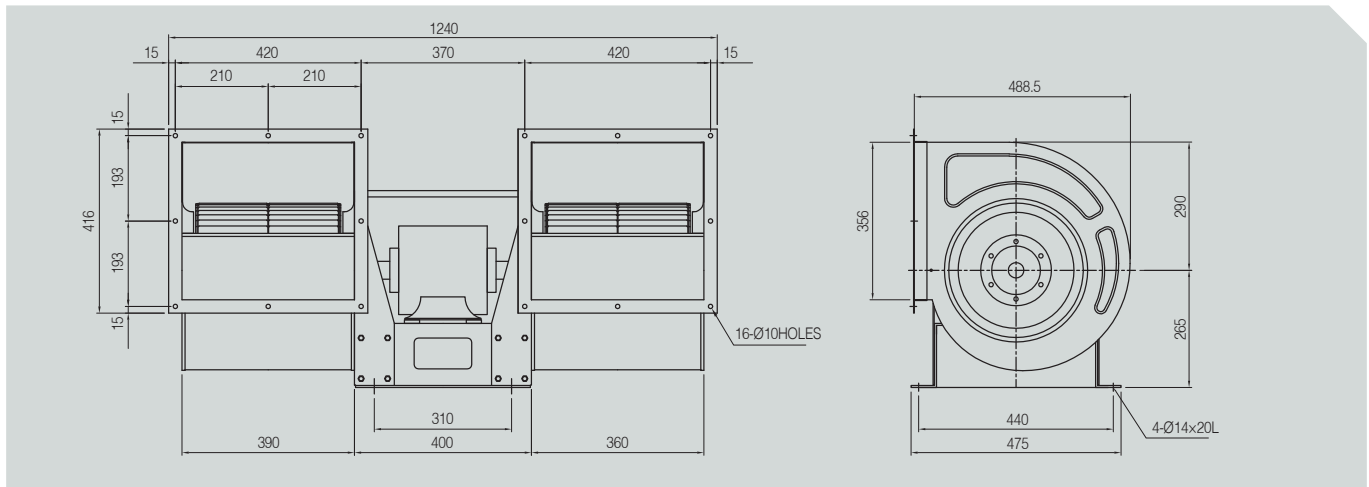

Power source			Static Pressure Pa	Air Volume CMM	Motor power W	Input power W	Current A	Rotative speed RPM
Phase	V	Hz						
∅ 3	220	60Hz	627	280	3700	4500	10	1120
	380							
∅ 3	220	50Hz	431	235	2120	2600	5.8	930
	380							

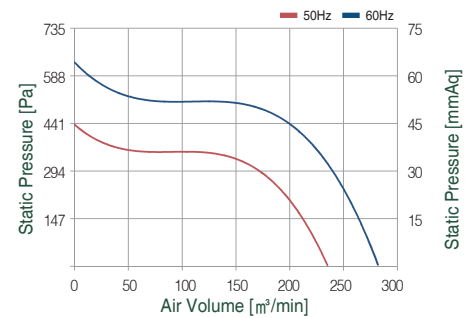

• AT-013-080

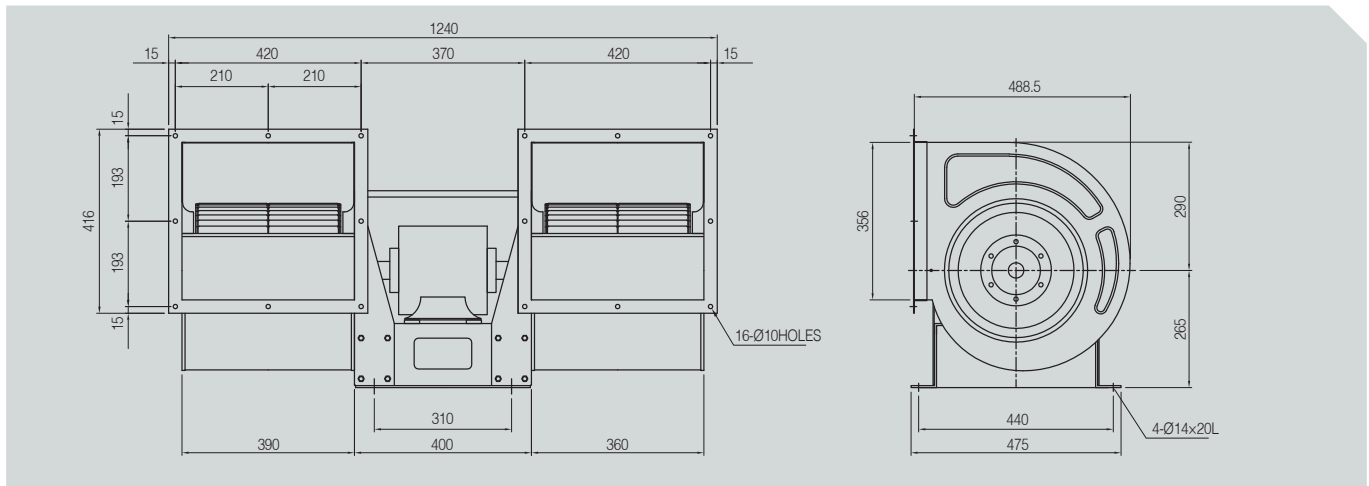

Power source			Static Pressure Pa	Air Volume CMM	Motor power W	Input power W	Current A	Rotative speed RPM
Phase	V	Hz						
∅ 3	220	60Hz	353	210	2200	3000	7.4	870
	380							
∅ 3	220	50Hz	245	175	1275	1740	4.3	720
	380							

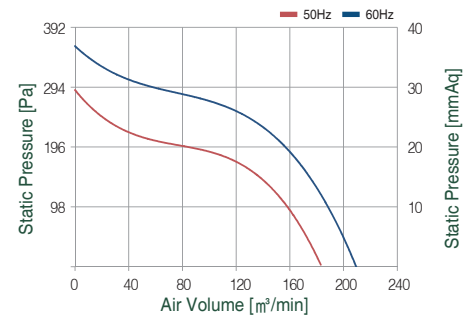

DOUBLE INLET TWIN FANS

• AT-015-080

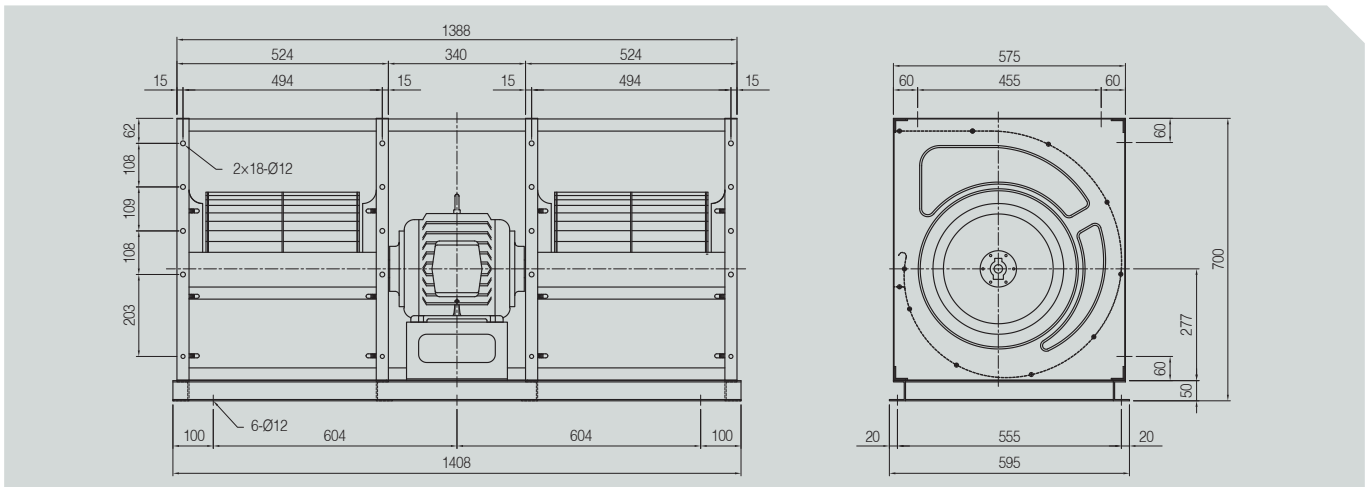

Power source			Static Pressure Pa	Air Volume CMM	Motor power W	Input power W	Current A	Rotative speed RPM
Phase	V	Hz						
∅ 3	380	60Hz	519	416	5500	3800	14	820

