

56R

HYBRID STEPPING MOTOR
S E R I E S

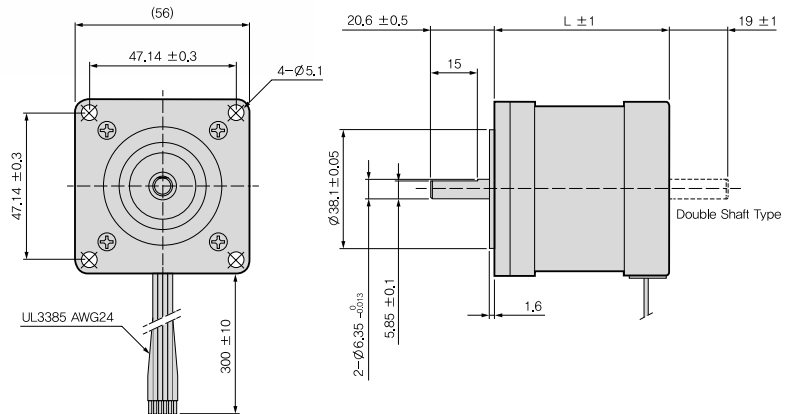

Dimension Specification



Wiring Diagram

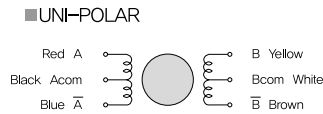

56R UNI-POLAR SPECIFICATIONS

Model No. (Drive Sequence)	Step Angle (Deg.)	Rated Voltage (V/Phase)	Rated Current (A/Phase)	Winding Resistance (Ω /Phase)	Inductance (mH/Phase)	Holding Torque (kgf · cm)	Rotor Inertia (g · cm ²)	Motor Length (L=mm)
4S56R-N12051S	1.8	12.0	0.6	20.0	30.0	5.0	120	51
4S56R-N02851S	1.8	2.8	2.0	1.4	2.0	5.0	120	51
4S56R-N12056S	1.8	12.0	0.6	20.0	38.0	6.0	155	56
4S56R-N06056S	1.8	6.0	1.2	5.0	9.8	6.0	155	56

OTHER SPECIFICATIONS AVAILABLE UPON REQUEST

- DRIVER CHOPPER
- SUPPLY VOLTAGE : DC 24.0V
- 2 PHASE EXCITING
- MOUNTING WITH RUBBER DAMPER

