

# 39Q

HYBRID STEPPING MOTOR  
S E R I E S

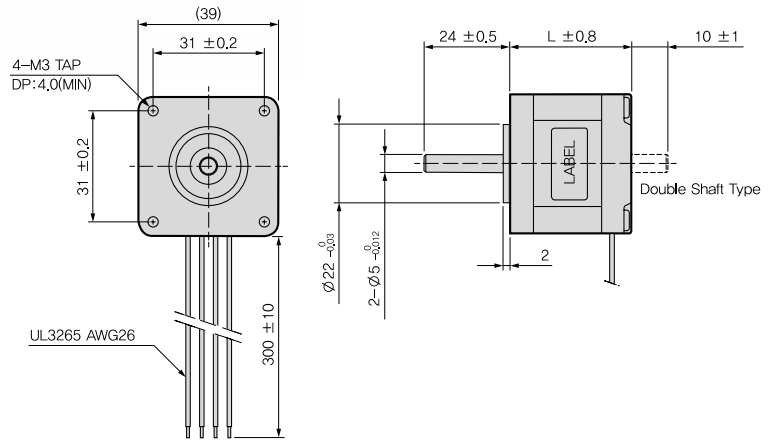

## Dimension Specification



## Wiring Diagram

### BI-POLAR

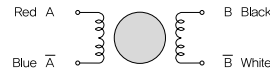

## 39Q BI-POLAR SPECIFICATIONS

Model No. (Drive Sequence)	Step Angle (Deg.)	Rated Voltage (V/Phase)	Rated Current (A/Phase)	Winding Resistance (Ω /Phase)	Inductance (mH/Phase)	Holding Torque (kgf · cm)	Rotor Inertia (g · cm <sup>2</sup> )	Motor Length (L=mm)
2S39Q-C08725S	1.8	8.7	0.6	14.5	10.5	1.3	16	25
2S39Q-C11234S	1.8	11.2	0.4	28.0	33.0	1.8	20	34

OTHER SPECIFICATIONS AVAILABLE UPON REQUEST

- DRIVER CHOPPER
- SUPPLY VOLTAGE : DC 24.0V
- 2 PHASE EXCITING
- MOUNTING WITH RUBBER DAMPER

