

# NTC Thermistor Sensors for Refrigeration

<b>Part Number</b>	7601 - 100002 (242290502)	
<b>Application</b>	Defrosting etc.	
<b>Function</b>	<ul style="list-style-type: none"> <li>• Temperature automatic control for defrost and for protecting the frozen rupture in the cold storage or freezing systems</li> <li>• Easy to install at the small or narrow space as slim shape</li> <li>• Small size with high contacting capacitance</li> <li>• Available waterproof and dustproof types with welding vinyl tube on the part</li> </ul>	
<b>Specification</b>	<b>Max Rated Watt</b>	100mW
	<b>Resistance Value</b>	10kΩ±1% @ 25°C
	<b>B(25/85) Value</b>	3970K±1%
	<b>Temperature Range</b>	-40°C to 105°C
	<b>Dielectric Withstand</b>	AC 1.8kV for 1 second
	<b>Insulation Resistance</b>	100MΩ Min.

(Picture)



• Any requirements for Connectors and Lead Wire are acceptable.

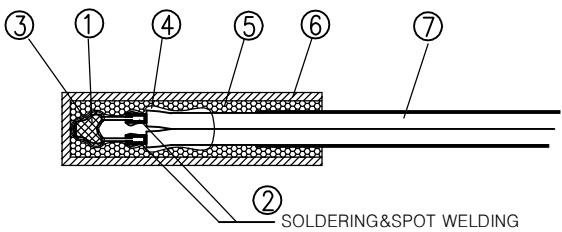
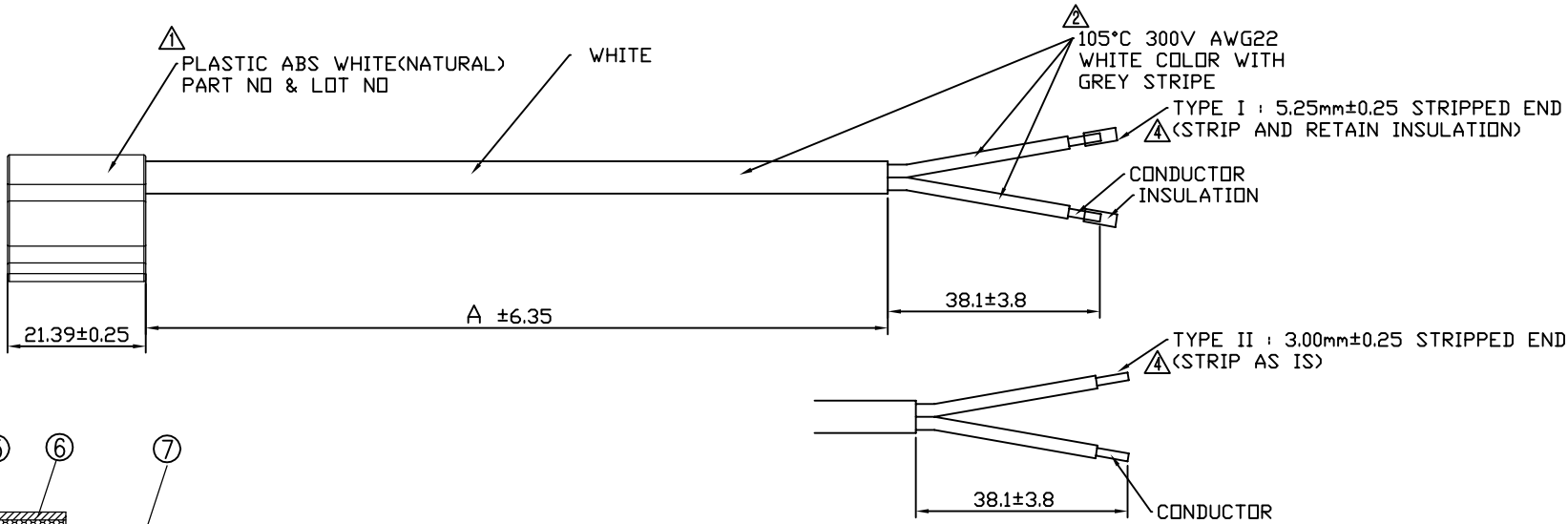
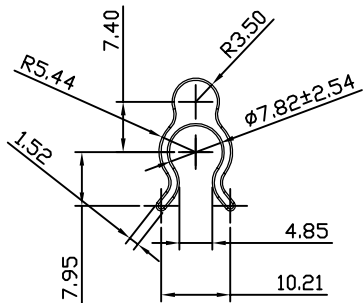

- NOTE**
1. OHMIC RESISTANCE  $10K\Omega \pm 1\%$  TO TEMPERATURE OF  $25^{\circ}C$
  2. B CONSTANT  $(25/85) = 3970K \pm 1.0\%$
  3. TEMPERATURE RANGE :  $-40^{\circ}C$  TO  $60^{\circ}C$
  4. UNLESS OTHERWISE SPECIFIED REFER TO REQUIREMENTS OF LATEST REVISION OF WIRING HARNESS SPEC. M.S. #1106.
  5. ELECTRPLUX PART NO & LOT NO. MUST APPEAR ON EACH HARNESS.
  6. WIRE HARNESS MUST MEET U.L. REQUIREMENTS OF SUBJECT #2517
  7. THERMISTOR NTC CHIP, EPOXY COATED.
  8. DOUBLE INSULATED CABLE, PVC/PVC, WHITE JACKET, 2xAWG#22, SUITABLE FOR  $-40^{\circ}C$  TO  $+105^{\circ}C$ .(300V)
  9. PLASTIC CAP CLIP, WHITE COLOR.
  10. WIRE COLOR NEEDS TO BE GRAY AND WHITE.
  11. INSULATION RESISTANCE :  $500VDC / 60s / 100M\Omega$
  12. ELETRIC STRENGTH :  $1250VAC / 60s$
  13. EXTRACTION RESISTANCE BETWEEN WIRE AND PACKAGE :  $3kgf / 60s$
  14. RT TABLE : REFER TO THE ATTACHMENT.

INCHANG P/N	ITTS P/N	ELECTROLUX P/N	"A" LENGTH	TYPE
7484-000013	ITTS-14A1	242290501	1676.40	I
7601-100002	ITTS-14A2	242290502	412.75	I
7601-100003	ITTS-14A3	242290503	476.25	I
△ 7601-100004	ITTS-14A4	242290504	254.00	I I
△ 7601-100005	ITTS-14A6	242290505	190.50	I
△ 7601-100006	ITTS-14A7	242290506	2306.00	I I

7	Lead Wire	1	105°C 300V AWG22 JACKET WHITE INSULATION WHITE COLOR WITH GREY STRIPE						
6	Case	1	ABS WHITE(NATURAL)						
5	Epoxy	2	ME105/HY-680 WHITE						
4	Epoxy	3	DN801/HB2360/ED44K BLACK						
3	Silicon	1	KR-255						
2	Solder	1	Pb Free						
1	Thermistor	1	LNTA103FW R25=10KΩ±1%						
NO	PARTS NAME	Q'TY	SPEC	REMARK					
SCALE	UNIT	TOLERANCE	DRAWING	CHECKED	APPROVED	NAME	SENSOR-DEFROST TEMP.		
-	MM	XXX = ±0.127	S. C. KIM			CODE NO.	ITTS-14A1 ~ 7		
			SEP-26-2014			USER CODE NO.	2422905MD	SHEET	/

SYM	REVISION	DESCRIPTION	DATE	REVISER	APPROVER
△		ADDED P/N AND TYPE II , CHANGED DIMENSION AND TOLERANCE	APR-09-2015		S.C.KIM
△		UL WIRE 2103 => 2517	OCT-01-2014		S.C.KIM
△		IN / OUT DOUBLE INSULATED CABLE 105°C / 80°C => 105°C / 105°C	SEP-25-2014		S.C.KIM
△		PBT PLASTIC CAP => ABS PLASTIC CAP	SEP-25-2014		S.C.KIM

INCHANG ELECTRONICS CO.,LTD.



## R-T data for LNTA 103FW

B25/85 3970 K  $\pm$  1%  
R25 10.00 k $\Omega$   $\pm$  1%

T( )	Rmin(k $\Omega$ )	Rcent(k $\Omega$ )	Rmax(k $\Omega$ )	DR(%)	DT( )
-40	332.9	348.4	364.6	4.65%	0.67
-39	311.3	325.6	340.5	4.58%	0.66
-38	291.2	304.4	318.1	4.51%	0.66
-37	272.6	284.7	297.3	4.44%	0.65
-36	255.3	266.4	278.1	4.37%	0.65
-35	239.2	249.5	260.2	4.30%	0.64
-34	224.2	233.7	243.6	4.23%	0.64
-33	210.2	219.0	228.1	4.17%	0.63
-32	197.3	205.4	213.8	4.10%	0.63
-31	185.2	192.7	200.4	4.03%	0.62
-30	173.9	180.8	188.0	3.97%	0.61
-29	163.4	169.8	176.4	3.90%	0.61
-28	153.6	159.5	165.6	3.84%	0.60
-27	144.5	149.9	155.6	3.77%	0.60
-26	135.9	141.0	146.2	3.71%	0.59
-25	127.9	132.6	137.4	3.64%	0.59
-24	120.5	124.8	129.3	3.58%	0.58
-23	113.5	117.5	121.6	3.52%	0.58
-22	107.0	110.7	114.5	3.46%	0.57
-21	100.9	104.3	107.8	3.40%	0.56
-20	95.13	98.32	101.6	3.34%	0.56
-19	89.77	92.72	95.76	3.27%	0.55
-18	84.75	87.48	90.30	3.21%	0.55
-17	80.04	82.57	85.18	3.15%	0.54
-16	75.62	77.97	80.38	3.10%	0.53
-15	71.47	73.65	75.89	3.04%	0.53
-14	67.58	69.60	71.67	2.98%	0.52
-13	63.93	65.80	67.72	2.92%	0.51
-12	60.49	62.23	64.01	2.86%	0.51
-11	57.26	58.87	60.53	2.81%	0.50
-10	54.22	55.72	57.25	2.75%	0.49
-9	51.37	52.76	54.18	2.69%	0.49
-8	48.68	49.97	51.28	2.64%	0.48
-7	46.15	47.34	48.57	2.58%	0.47
-6	43.76	44.87	46.01	2.53%	0.47
-5	41.52	42.55	43.60	2.47%	0.46
-4	39.40	40.36	41.33	2.42%	0.45
-3	37.40	38.29	39.20	2.37%	0.45
-2	35.52	36.34	37.18	2.31%	0.44
-1	33.74	34.51	35.29	2.26%	0.43
0	32.06	32.78	33.50	2.21%	0.43

T( )	Rmin(k $\Omega$ )	Rcent(k $\Omega$ )	Rmax(k $\Omega$ )	DR(%)	DT( )
1	30.48	31.14	31.81	2.15%	0.42
2	28.98	29.60	30.22	2.10%	0.41
3	27.57	28.14	28.72	2.05%	0.40
4	26.23	26.76	27.30	2.00%	0.40
5	24.97	25.46	25.96	1.95%	0.39
6	23.78	24.23	24.69	1.90%	0.38
7	22.64	23.07	23.49	1.85%	0.37
8	21.57	21.96	22.36	1.80%	0.37
9	20.56	20.92	21.29	1.75%	0.36
10	19.60	19.94	20.27	1.70%	0.35
11	18.69	19.00	19.31	1.65%	0.34
12	17.83	18.12	18.41	1.60%	0.34
13	17.01	17.28	17.55	1.55%	0.33
14	16.24	16.48	16.73	1.51%	0.32
15	15.50	15.73	15.96	1.46%	0.31
16	14.80	15.01	15.22	1.41%	0.30
17	14.14	14.33	14.53	1.36%	0.30
18	13.51	13.69	13.87	1.32%	0.29
19	12.91	13.08	13.24	1.27%	0.28
20	12.35	12.50	12.65	1.23%	0.27
21	11.81	11.95	12.09	1.18%	0.26
22	11.29	11.42	11.55	1.13%	0.25
23	10.81	10.92	11.04	1.09%	0.24
24	10.34	10.45	10.56	1.04%	0.24
25	9.900	10.00	10.10	1.00%	0.23
26	9.472	9.571	9.671	1.04%	0.24
27	9.064	9.164	9.263	1.09%	0.25
28	8.676	8.776	8.875	1.13%	0.26
29	8.308	8.406	8.505	1.18%	0.27
30	7.956	8.054	8.152	1.22%	0.29
31	7.622	7.719	7.816	1.26%	0.30
32	7.303	7.399	7.496	1.30%	0.31
33	7.000	7.095	7.191	1.35%	0.32
34	6.711	6.805	6.899	1.39%	0.33
35	6.435	6.528	6.621	1.43%	0.35
36	6.172	6.264	6.356	1.47%	0.36
37	5.922	6.012	6.103	1.52%	0.37
38	5.682	5.771	5.861	1.56%	0.38
39	5.454	5.542	5.631	1.60%	0.40
40	5.236	5.323	5.410	1.64%	0.41



### R-T data for LNTA 103FW

B25/85 3970 K  $\pm$  1%  
R25 10.00 k $\Omega$   $\pm$  1%

T( )	Rmin(k $\Omega$ )	Rcent(k $\Omega$ )	Rmax(k $\Omega$ )	DR(%)	DT( )
41	5.029	5.114	5.199	1.68%	0.42
42	4.830	4.914	4.998	1.72%	0.44
43	4.640	4.723	4.806	1.76%	0.45
44	4.459	4.540	4.622	1.80%	0.46
45	4.286	4.366	4.446	1.84%	0.47
46	4.121	4.199	4.278	1.88%	0.49
47	3.963	4.039	4.117	1.92%	0.50
48	3.811	3.886	3.962	1.96%	0.51
49	3.667	3.740	3.815	2.00%	0.53
50	3.528	3.600	3.674	2.04%	0.54
51	3.396	3.466	3.538	2.08%	0.55
52	3.269	3.338	3.409	2.11%	0.57
53	3.147	3.216	3.285	2.15%	0.58
54	3.031	3.098	3.166	2.19%	0.59
55	2.920	2.985	3.052	2.23%	0.61
56	2.813	2.877	2.943	2.27%	0.62
57	2.711	2.774	2.838	2.30%	0.64
58	2.613	2.675	2.737	2.34%	0.65
59	2.519	2.579	2.641	2.38%	0.66
60	2.429	2.488	2.548	2.41%	0.68
61	2.343	2.401	2.459	2.45%	0.69
62	2.260	2.317	2.374	2.49%	0.71
63	2.181	2.236	2.292	2.52%	0.72
64	2.104	2.158	2.214	2.56%	0.74
65	2.031	2.084	2.138	2.60%	0.75
66	1.961	2.013	2.066	2.63%	0.77
67	1.893	1.944	1.996	2.67%	0.78
68	1.829	1.878	1.929	2.70%	0.80
69	1.766	1.815	1.865	2.74%	0.81
70	1.707	1.754	1.803	2.77%	0.83
71	1.649	1.696	1.743	2.81%	0.84
72	1.594	1.639	1.686	2.84%	0.86
73	1.541	1.585	1.631	2.88%	0.87
74	1.490	1.533	1.578	2.91%	0.89
75	1.441	1.483	1.527	2.95%	0.90
76	1.393	1.435	1.478	2.98%	0.92
77	1.348	1.389	1.431	3.01%	0.93
78	1.304	1.344	1.385	3.05%	0.95
79	1.262	1.301	1.341	3.08%	0.96
80	1.222	1.260	1.299	3.11%	0.98

T( )	Rmin(k $\Omega$ )	Rcent(k $\Omega$ )	Rmax(k $\Omega$ )	DR(%)	DT( )
81	1.183	1.220	1.258	3.15%	1.00
82	1.145	1.181	1.219	3.18%	1.01
83	1.109	1.145	1.181	3.21%	1.03
84	1.074	1.109	1.145	3.25%	1.04
85	1.040	1.075	1.110	3.28%	1.06
86	1.008	1.041	1.076	3.31%	1.08
87	0.9767	1.009	1.043	3.34%	1.09
88	0.9467	0.9787	1.012	3.37%	1.11
89	0.9176	0.9490	0.9813	3.41%	1.12
90	0.8897	0.9204	0.9520	3.44%	1.14
91	0.8627	0.8927	0.9237	3.47%	1.16
92	0.8367	0.8660	0.8964	3.50%	1.17
93	0.8115	0.8403	0.8700	3.53%	1.19
94	0.7873	0.8154	0.8445	3.56%	1.21
95	0.7639	0.7914	0.8199	3.59%	1.22
96	0.7413	0.7683	0.7961	3.63%	1.24
97	0.7195	0.7459	0.7731	3.66%	1.26
98	0.6984	0.7242	0.7509	3.69%	1.28
99	0.6781	0.7033	0.7295	3.72%	1.29
100	0.6584	0.6831	0.7087	3.75%	1.31
101	0.6394	0.6636	0.6887	3.78%	1.33
102	0.6210	0.6448	0.6693	3.81%	1.35
103	0.6033	0.6265	0.6506	3.84%	1.36
104	0.5861	0.6089	0.6324	3.87%	1.38
105	0.5696	0.5918	0.6149	3.90%	1.40
106	0.5535	0.5753	0.5979	3.93%	1.42
107	0.5380	0.5593	0.5815	3.95%	1.43
108	0.5230	0.5439	0.5655	3.98%	1.45
109	0.5085	0.5289	0.5501	4.01%	1.47
110	0.4944	0.5144	0.5352	4.04%	1.49
111	0.4808	0.5004	0.5208	4.07%	1.51
112	0.4676	0.4868	0.5068	4.10%	1.52
113	0.4549	0.4737	0.4933	4.13%	1.54
114	0.4425	0.4610	0.4801	4.16%	1.56
115	0.4306	0.4486	0.4674	4.18%	1.58
116	0.4190	0.4367	0.4551	4.21%	1.60
117	0.4078	0.4251	0.4431	4.24%	1.62
118	0.3969	0.4139	0.4315	4.27%	1.64
119	0.3863	0.4030	0.4203	4.30%	1.65
120	0.3761	0.3924	0.4094	4.32%	1.67

LNTA103FW RT Graph

