

BRUSHLESS DC MOTOR UNIT - B Series

DIMENSIONS

K8BH40N■ + K8H□BTH

(Weight : 2.3Kg)

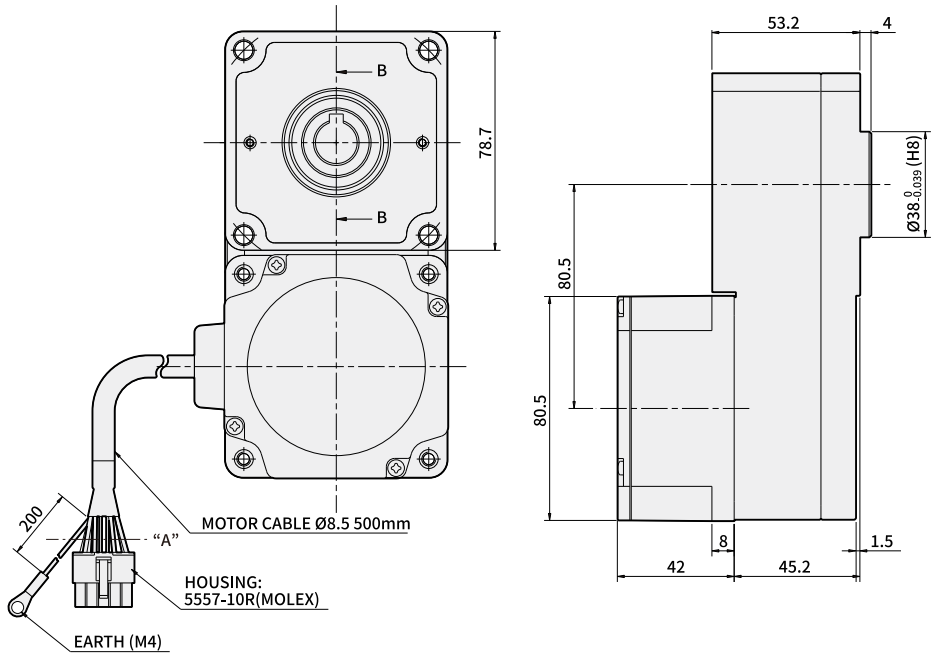

* KEY · KEY GROOVE (ACCESSORY)

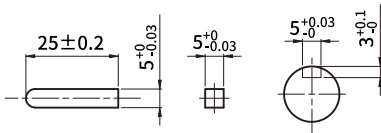

* CONNECTOR HOUSING (VIEW A)

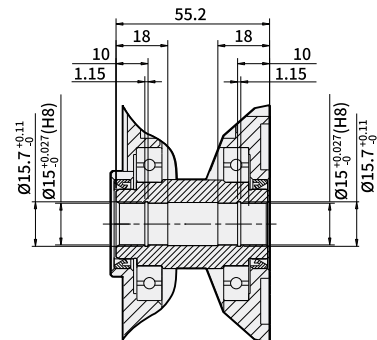
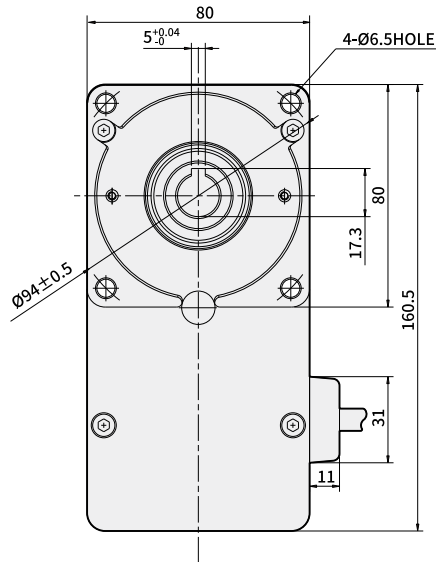
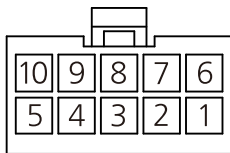

SECTION B-B

* PIN MAP

MOTOR PRODUCT NAME	GEARHEAD PRODUCT NAME	DECELERATION RATIO	FIXING BOLT
K8BH40N■	K8H□BTH	5~200	M6 P1.0×70

PIN No.	COLOR	SIGNAL
1	BLUE	U
2	-	-
3	GREEN	Ground
4	YELLOW	Vcc
5	ORANGE	Hw
6	PURPLE	V
7	GRAY	W
8		(Drain)
9	BROWN	Hu
10	WHITE	Hv

* In Dimension, in ■ of name represents power voltage U(single-phase 100~115V), C(single-phase 200~230V)

* In □ of name, it represents a deceleration ratio.

* Mounting bolt sets are included in flat type gearbox.

M6×70L (flat washer, spring washer, hexagonal nut 4pcs each)

→ Specification

Product name	Gear type	K6BH20NU	K6BH20NC	K8BH40NU	K8BH40NC	K9BH90NU	K9BH90NC	K9BH150NC	K9BH200NC	
	D-cut type	K6BS20NU	K6BS20NC	K8BS40NU	K8BS40NC	K9BS90NU	K9BS90NC	K9BS150NC	K9BS200NC	
Rating output (continuous)	W	20		40		90		150	200	
Power input	Voltage	V	100~115	200~230	100~115	200~230	100~115	200~230	200~230	
	Frequency	Hz	50/60							
	Rating input current	A	0.95	0.55	1.45	0.85	2.55	1.45	2.1	2.5
	Maximum input current	A	1.55	0.9	2.5	1.4	3.9	2.4	4	4
Rating torque	N·m(kgf·cm)	0.1(1.0)		0.2(2.0)		0.45(4.5)		0.49(4.9)	0.65(6.5)	
Starting torque	N·m(kgf·cm)	0.12(1.2)		0.24(2.4)		0.54(5.4)		0.63(6.3)	0.81(8.1)	
Rating rotation speed	r/min	2,000						3,000		
Speed control range	r/min	100~2,000						100~3,000		
Motor allowed load inertia moment	J kg·m ²	0.5×10 ⁻⁴		1.8×10 ⁻⁴		5.8×10 ⁻⁴		5.8×10 ⁻⁴	6.0×10 ⁻⁴	
	GD ² kgf·cm ²	2		7.2		23.2		23.2	24	
Speed change rate	Load	less than or equal to ±1% (0~Rating torque, If rotating at the rated speed)								
	Voltage	less than or equal to ±1% (Power voltage ±10%, If rotation at the rated speed No load)								
	Temperature	less than or equal to ±1% (0~+40℃, If rotation at the rated speed No load)								

→ Common Specification

Items	Specifications
Rotation speed setting method	Controller panel's speed
Acceleration time/ deceleration time	0.5~10 seconds : 2000r/min no load (It may change depending on the load size). To set acceleration time, it is set at slow start on the front panel. To set deceleration time, it is set at slow stop.
Input signal	Photo coupler input method, operating at input resistance of 10kΩ DC 12V±10%, Common in EXT, CW, and CCW
Output signal	Open collector output, External use conditions: less than 26.4V 10mA, common in SPEED OUT/ALARM OUT
Protection function	If the following protection function is operating, then control unit alarm signal gets generated and motor stops automatically. <ul style="list-style-type: none"> ● Overload protection function : If more than the rated torque is applied to the motor for more than 5 seconds ● Overvoltage protection function : If voltage applied to the control unit goes over the upper bound of the rating voltage allowance ● Open phase protection : If cable sensor line gets disconnected during motor operation ● Undervoltage protection : If voltage applied to the control unit is less than the lower bound of the rating voltage allowance ● Over speed protection : If motor rotation speed is faster than 2500r/min
Motor insulation class	E Type(120℃)
Maximum extension distance	The distance between motor-control unit is 10.5m (optional KBEW-10 extension cable is used)
Rated time	Continuous

→ Normal specifications

Items		Motor	Control unit
Insulation Resistance		After continuously operating at room temperature and humidity, it should be greater than 100M Ω between coil and case when measured with DC 500V MEGA TESTER	Protection ground terminal and power input should be greater than 100M Ω when measured with DC 500V MEGA TESTER
Dielectric Strength		After continuously operating at room temperature and humidity, there shouldn't be any problem if 60Hz, 1500V is applied for more than 1 minute between coil and case	There shouldn't be any problem if 60Hz, 1500V is applied for more than 1 minute between protection ground terminal and power input
Temperature rise		After operating continuously at room temperature and humidity, the temperature increase should be less than 60 $^{\circ}$ C and less than 50 $^{\circ}$ C of temperature increase on the case surface when measured with thermo couple	
Used environment	Used Ambient temperature	0 $^{\circ}$ C~+40 $^{\circ}$ C (There should not be any freeze)	
	Used Ambient Humidity	less than 85% (no dew condensation)	
	Ambient environment	No corrosive gas or dusts	
Conservation environment	Ambient temperature	-25 ~ +70 $^{\circ}$ C (There should not be any freeze)	
	Ambient Humidity	less than 85% (no dew condensation)	
Protection class		IP65(Except for the mounting part on the output part)	IP10

→ Allowed torque of combination type

Unit = Upper part : N·m / lower part : kgf·cm

Items	Deceleration ratio	5	10	15	20	30	50	100	200
	Speed control range [r/min]	20~400	10~200	6.7~133	5~100	3.3~67	2~40	1~20	0.5~10
K6BH20N■ + K6H□B	0.45 4.5	0.9 9	1.4 14	1.8 18	2.6 26	4.3 43	6 60	6 60	
K8BH40N■ + K8H□B	0.9 9	1.8 18	2.7 27	3.6 36	5.2 52	8.6 86	16 160	16 160	
K9BH90N■ + K9H□B	2 20	4.1 41	6.1 61	8.1 81	11.6 116	19.4 194	30 300	30 300	
K9BH150NC + K9H□B	2.4 24	4.7 47	7.1 71	9.5 95	13.6 136	22.7 227	30 300	30 300	
K9BH200NC + K9H□B	3 30	6.1 61	9.1 91	12.2 122	17.5 175	29.2 292	30 300	30 300	
K6BH20N■ + K6H□BTH	0.4 4	0.85 8.5	1.3 13	1.7 17	2.6 26	4.3 43	8.5 85	17 170	
K8BH40N■ + K8H□BTH	0.85 8.5	1.7 17	2.6 26	3.4 34	5.1 51	8.5 85	17 170	34 340	
K9BH90N■ + K9H□BTH	1.9 19	3.8 38	5.7 57	7.7 77	11.5 115	19.1 191	38.3 383	68 680	
K9BH150NC + K9H□BTH	2.0 20	4.1 41	6.2 62	8.3 83	12.4 124	20.8 208	41.6 416	68 680	
K9BH200NC + K9H□BTH	2.7 27	5.5 55	8.2 82	11 110	16.5 165	27.6 276	55.2 552	68 680	

- * Rotation direction shows the same color as the motor. In other cases, it's the opposite.
- * Flat Gearbox viewed from front side is opposite rotation direction with motor.
Flat Gearbox viewed from back side is same rotation direction with motor.

→ Allowed overhang load and allowed thrust

Items		Deceleration ratio	Allowed overhang load				Allowed thrust load	
			From the end of output part 10mm		From the end of output part 20mm		N	kgf
			N	kgf	N	kgf		
GEARED MOTOR	K6BH20N■ + K6H□B	5	100	10	150	15	40	4
		10~20	150	15	200	20		
		30~200	200	20	300	30		
	K8BH40N■ + K8H□B	5	200	20	250	25	100	10
		10~20	300	30	350	35		
		30~200	450	45	550	55		
	K9BH90N■ + K9H□B	5	300	30	400	40	150	15
		10~20	400	40	500	50		
		30~200	500	50	650	65		
	K9BH150NC + K9H□B	5	300	30	400	40	150	15
		10~20	400	40	500	50		
		30~200	500	50	650	65		
	K9BH200NC + K9H□B	5	300	30	400	40	150	15
		10~20	400	40	500	50		
		30~200	500	50	650	65		
	K6BH20N■ + K6H□BTH	5~10	450	45	370	37	200	20
		15~200	500	50	400	40		
	K8BH40N■ + K8H□BTH	5~10	800	80	660	66	400	40
		15~200	1200	120	1000	100		
	K9BH90N■ + K9H□BTH	5~10	900	90	770	77	500	50
		15~20	1300	130	1110	111		
		30~200	1500	150	1280	128		
	K9BH150NC + K9H□BTH	5~10	900	90	770	77	500	50
		15~20	1300	130	1110	111		
30~200		1500	150	1280	128			
K9BH200NC + K9H□BTH	5~10	900	90	770	77	500	50	
	15~20	1300	130	1110	111			
	30~200	1500	150	1280	128			
MOTOR	K6BS20N■		70	7	100	10	· Be careful not to take thrust load. If it's inevitable, keep it under 50% of the motor weight.	
	K8BS40N■		120	12	140	14		
	K9BS90N■		160	16	170	17		
	K9BS150NC		160	16	170	17		
	K9BS200NC		160	16	170	17		

* In dimension, in ■ of name represents power voltage U(single-phase 100~115V),and C(single-phase 200~230V).

* In □ of name, it represents a deceleration ratio.

→ Rotation speed - torque characteristic

K6BS20N ■ / K6BH20N ■

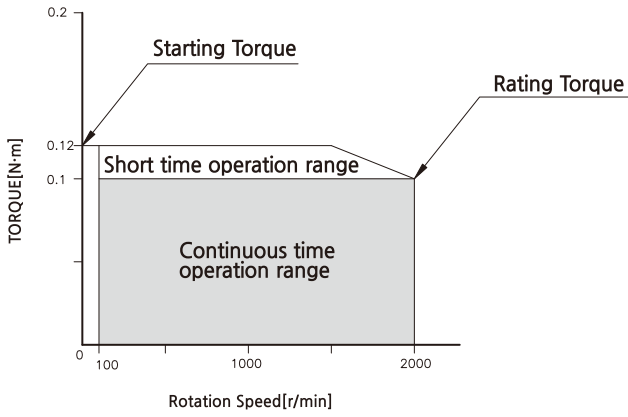

K8BS40N ■ / K8BH40N ■

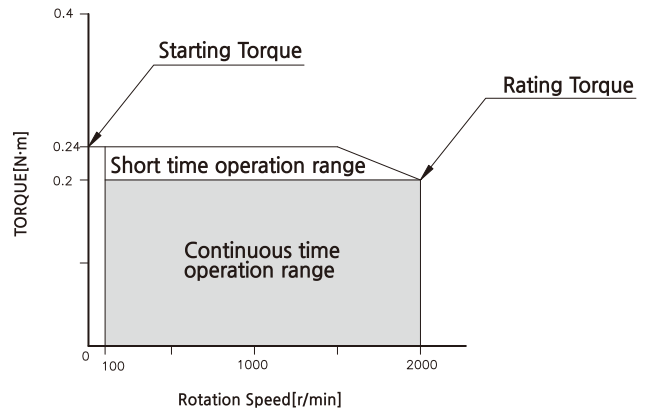

K9BS90N ■ / K9BH90N ■

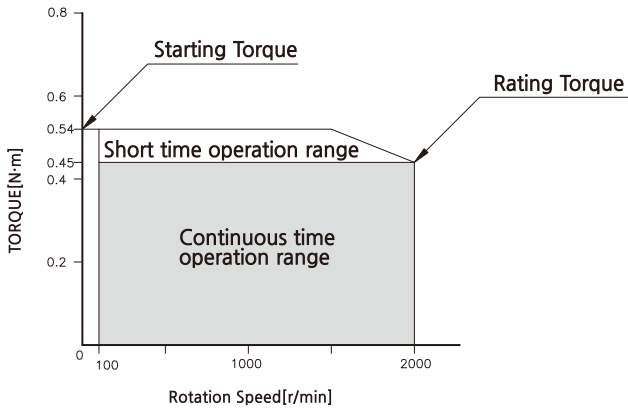

K9BS150NC / K9BH150NC

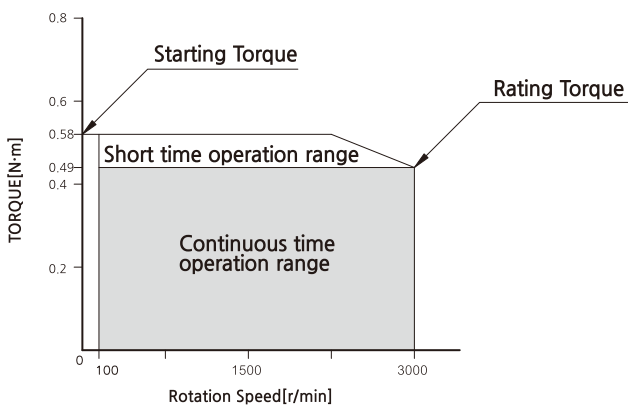

K9BS200NC / K9BH200NC

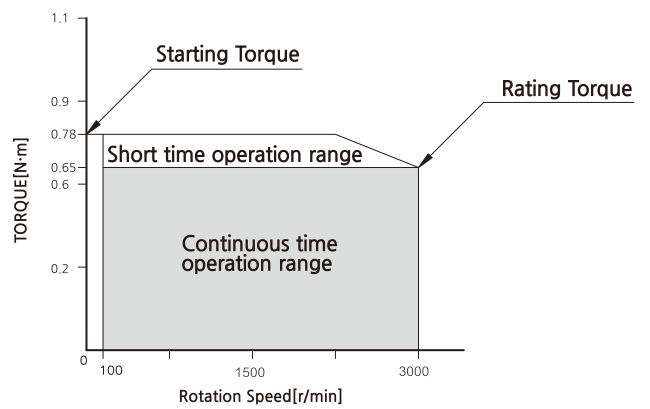

* In Dimension, in ■ of name represents power voltage U(single-phase 100~115V), C(single-phase 200~230V)