

BLDC SPEED CONTROL UNIT

GUL

L Series motor applied product

→ Product appearance

■ GUL-2-30(DC 24V, for 30W) / GUL-2-50(DC 24V, for 50W)

● Driver main part outside view

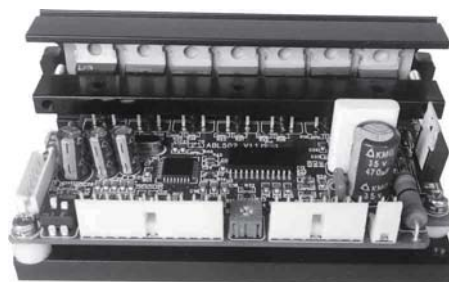
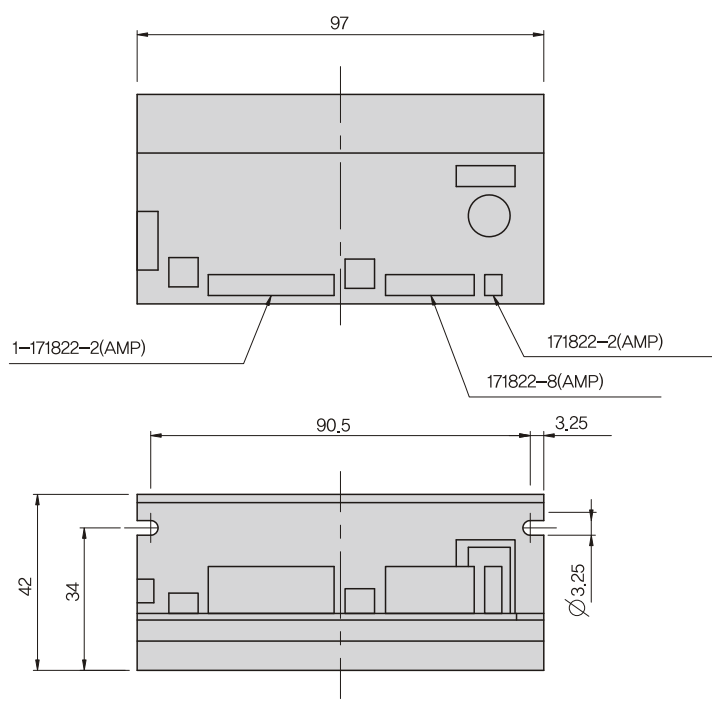

● Driver input signal cable, External volume

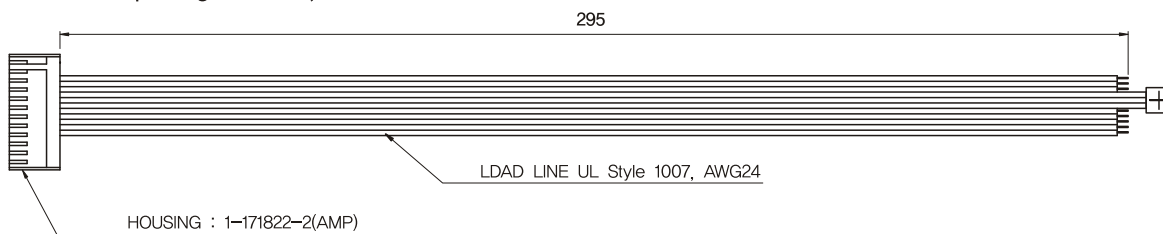

● Driver power cable

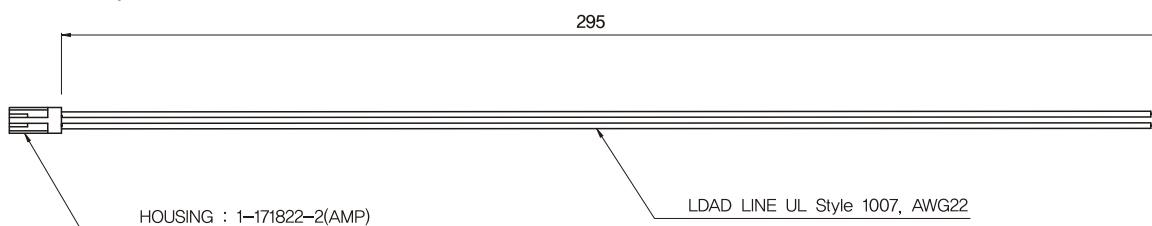

■ GUL-2-100(DC 24V, for 100W)

● Driver main part outside view

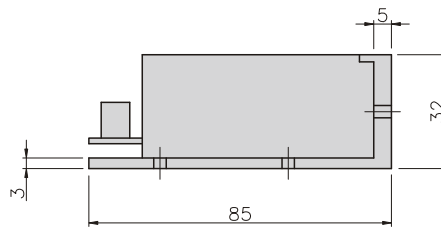
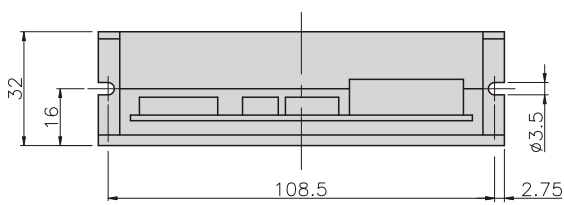
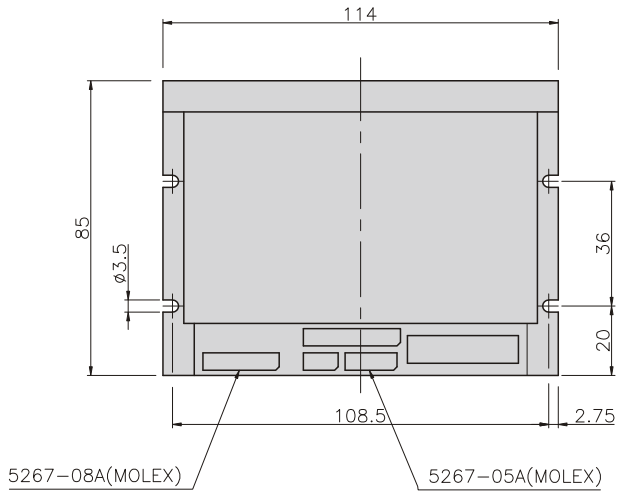

● Driver input signal cable, External volume

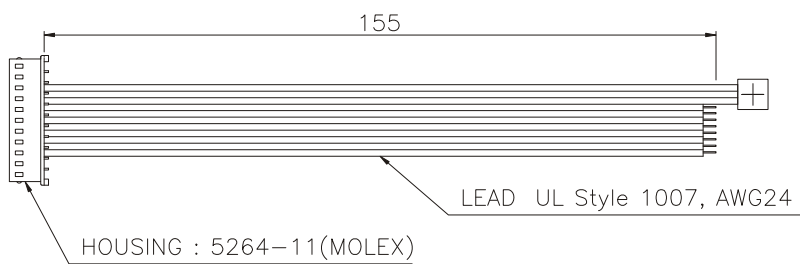

→ Name and functions of each part

- GUL-2-30(DC 24V, for 30W) / GUL-2-50(DC 24V, for 50W)

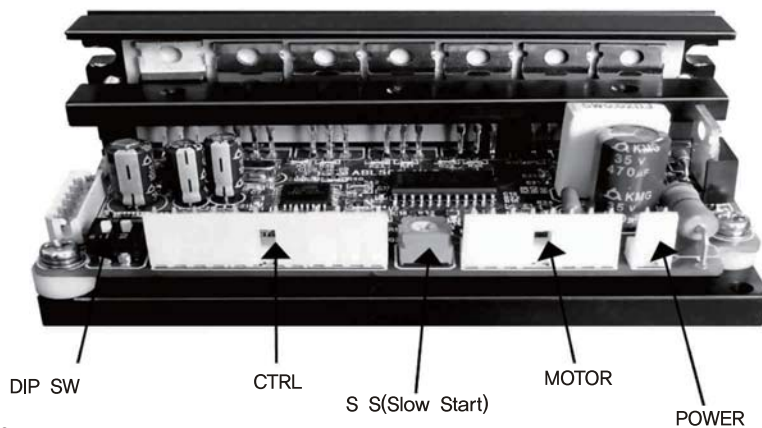

1. Input/output specification

Items	Details	Note
External size	97×50×42	
Power input, Controller output	DC12~26V rated current 2A, Maximum current 5A	
Operation object	DC24V, BLDC Motor	
Control	Input signal type: pull-up, Output signal type: open-collector	PLC connected control

2. Input/output signals

- CTRL(AMP,171825-12)

Pin No.	Signal name	Direction	Color	Explanation
1	ALARM	OUT	Brown	If control unit is under alarm or overload, then the signal line becomes H (5V) and LED turns on, If there is problem with motor connection, LED turns on, Under the normal condition, it is turned off (Gnd) and LED gets turned off also.
2	SPEED_OUT	OUT	RED	Pulse gets released according to the image changes in the motor in response to BLDC motor speed. The number of pulse per 1 motor rotation is as follows depending on the characteristic of motor 4pole:6pulse/rotation, 8pole:12ppr, 10pole:15ppr, 12pole:18ppr
3	GND	Ground	Orange	
4	GND	Ground	Yellow	
5	SPEED_IN	IN	Green	It is direct power input for speed control. The range is between 0V and 5V. Within this range, motor gets controlled proportionally.
6	5V	OUT	Blue	Supplying direct power (DC5V) should be used as variable resistant Vcc to input speed with support from outside. It should not be used for any other purposes.
7	ALM_RESET	IN	Purple	If control unit stops due to overload, then remove the source of alarm and forcefully restart, ON→ OFF then RESTART.
8	CHG	—	Brown	If it is on, then internal S_S volume is used to control speed. If it is off, then S_S volume is used to set acceleration and deceleration times.
9	CW/CCW	IN	Gray	If you look at from the axis, when the signal wire is connected with GND, then it rotates CW. In other cases, it rotates CCW.
10	RUN/BRAKE	IN	White	If it is on (L), then the motor operates, If you turn it to off during motor operation, then it stops instantaneously. (Brake on) If signal wire is off, then the motor does not operate. Wait a few minutes before restarting (after brake on).
11	START/STOP	IN	Black	If it is on, then the motor is ready to rotate. If you turn it to off during motor operation, then it stops automatically.
12	NC			

3. LED Specifications

No.	Sign	Color	Details
1	STATUS	GREEN	It flickers every 1 second under normal condition
2	ALARM	RED	It flickers if system is overloaded. If there is problem with motor whole sensor, then it turns on.

4. DIP Switch specification

Pin No.	Status	COLOR	Details	Model name	Applied motor
1	OFF	GREEN	Maximum limit current 3,5A	GUL-2-30	K6L□30N2
	ON	RED	Maximum limit current 5A	GUL-2-50	K8L□50N2

Motor operation condition depending on the signal condition

START/STOP	RUN/BRAKE	Operation status
ON(L)	ON(L)	Normal operation
ON(L)	OFF(H)	Instant stop
ON(H)	ON(L)	Automatic stop due to inertia of motor and load

5. Variable resistance

- Setting acceleration and deceleration speeds: S_S(SLOW START)

Slope of motor's acceleration and deceleration is decided. Acceleration and deceleration are possible in parallel with variable resistance, VR2's output voltage. If the variable resistance is at minimum, then the time it takes motor to reach the maximum speed from the stop is 10 seconds. If variable resistance at maximum (at maximum value, greater than 90%, greater than 9 markings), then it takes about 0,1 sec to reach the maximum speed. If you need to rapidly accelerate or decelerate, then you should keep the resistance marking at 9 (at maximum).

- External variable resistance for speed control (SPEED_IN)

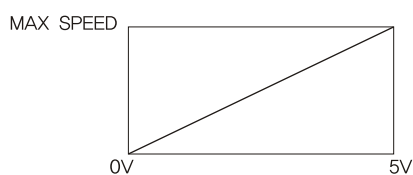

Motor speed vs. external voltage : SPEED_IN

■ GUL-2-100(DC 24V, for 100W)

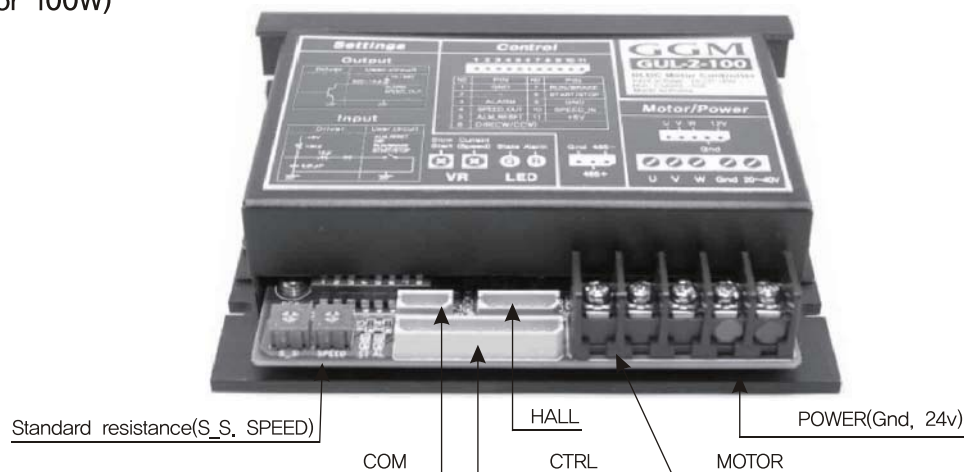

1. Input/output specifications

Items	Details	Note
External size	114X85X32 (Case included)	
Power input, Controller output	DC12~36V, Normal 10A	
Signal system	Input signal type: pull-off, Output signal type: open-collector	PLC connected control
Communication(Optional)	RS485 1ch, 9,600bps	PLC connected control

2. Input/output signals

Signal line is at pull-up internally. If it is L (GND), in other words, if the signal line is connected with GND or if electric potential is at GND level, NC (disconnected with GND), then it gets turned off.

Pin No.	Signal name	Direction Color	Details
1	GND	Black	Ground
2	INT_SPEED	IN Green	ON : control the speed using internal volume (speed) OFF : Speed uses external volume, and speed signal sets the maximum current value for motor.
3	ALARM	OUT Purple	Control unit's alarm signal, if it is alarmed because of overload then signal line gets turned on (GND) and LED light flashes every second. If there is problem with motor connection, then LED gets turned on. Under the normal operation, it is off (high) and LED gets turned off.
4	SPEED_OUT	OUT Orange	Pulse gets released according to the image changes in the motor in response to BLDC motor speed. The number of pulse per 1 motor rotation is as follows depending on the characteristic of motor. 4 poles: 6 pulses/ rotation, 8 poles: 12ppr, 10 poles: 15ppr, 12 poles: 18ppr
5	ALM_RESET	IN Grey	If control unit stops due to overload, then remove the source of alarm and forcefully restart. ON→ OFF then RESTART.
6	DIR	IN Brown	Determine the rotation direction of motor. Rotation direction is when you look at it from output axis of motor. If signal line is connected to GND, then it is CW. In other cases, it rotates CCW. If the #8 pin CHG of DIP switch is on, then motor rotates CW when DIR signal is on. When it is controlled through telecommunication, then CW (→) direction should be short-circuited with GND to operate (can be used with limit switch input).

7	RUN/BRAKE	IN White	If it is on (L), then the motor operates. If you change it to off during motor operation, then it stops instantly. (Brake on) If signal line is off, then the motor does not operate. Restart after operating brake for a certain amount of time.
8	START/STOP	IN Magenta	If it is on, then the motor is ready to rotate. If you change it to off during motor operation, then it stops instantly. If the #8 pin CHG of DIP switch is on, then motor rotates CCW when START/STOP signal is on. When it is controlled through telecommunication, then CCW (+) direction should be short-circuited with GND to operate (can be used with limit switch input).
9	GND	Blue	Ground
10	SPEED_IN	IN Yellow	This is direct current power input for speed setting The range is between 0 and 5V. in this range, the motor is controlled throughout the entire range proportionally.
11	5V	OUT Red	Supplying direct current (DC5V) It is used for variable resistance Vcc to input speed with support from outside. It should not be used for any other purposes.

In order to operate motor, run/brake and start/stop should be on. Then, input the desired speed and direction at DIR (CW/CCW). Speed input is supplied by SPEED_IN. While operating motor, if you turn run/brake off, then the motor stops instantly. If run/brake signal is on and start/stop is off, then the motor stops automatically.

3. LED SPECIFICATION

No.	Naming	Color	Details
1	ALARM	RED	System overload flashes in system overload(Motor whole sensor signal problem light on)
2	STATUS	GREEN	Normal operating condition flashes every second

4. DIP Switch specification

Dip name	Pin No.	Naming(mark)	Details	Note
8PIN DIP	1~4	DIP1~4	Select a motor that needs to be controlled by control unit.	Refer to the table below
	5	INV	If motor speed signal is the opposite, then the control unit gets sudden overspeed. This pin is used and its setting is different for each motor.	
	6			
	7	OPEN	Control motor with open-loop. It does not use speed feedback. It creates output that is parallel to the variable resistance set by the user.	Open-loop, Closed-loop
	8	CHG	If it is on, CTRL connector's direction setting DIR signal is controlled by CW signal and START/STOP signal is by CCW signal.	

STATE	CW	CCW
TQ OFF	OFF	OFF
CW ROTATION	ON	OFF
CCW ROTATION	OFF	ON
BRAKE	ON	ON

- The DIP SW settings (DIP1, DIP2, DIP3, DIP4)

Number of pole (SW1, SW2)						Max. RPM(SW3, SW4)			
NO	DIP1	DIP 2	Pole	Pulse/Rev	Min. RPM	NO	DIP 3	DIP 4	RPM
0	OFF	OFF	4	6	50	0	OFF	OFF	1800
1	ON	OFF	8	12	50	1	ON	OFF	2000
2	OFF	ON	10	15	50	2	OFF	ON	3000
3	ON	ON	12	18	50	3	ON	ON	5000

- Motor operation condition depending on the signal condition

START/STOP	RUN/BRAKE	Operation status
ON(L)	ON(L)	Normal operation
ON(L)	OFF(H)	Instant stop
OFF(H)	ON(L)	Automatic stop due to inertia of motor and load

- Input/output signals in the form(User Control connection-related)

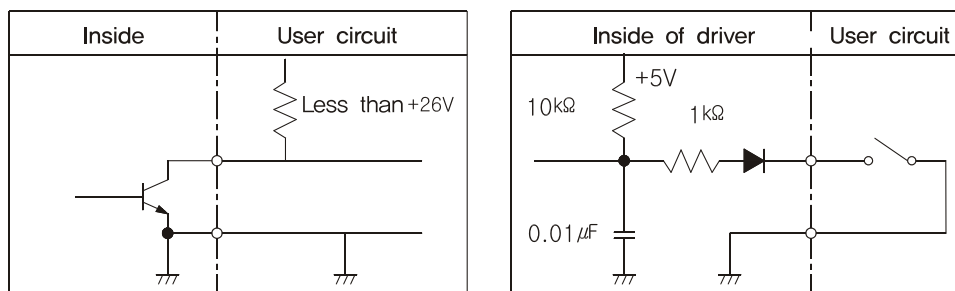

- Motor connector specification

Name	Pin	Pin name	Function	Remark(Connector)
MOT_SEN (5P CNT)	1,2,3	Hw, Hv, Hu	Hall sensor signal input	Molex, 5267-05
	4,5	Gnd, 12V	Hall sensor power	
MOTOR	1,2,3	U, V, W	Motor power line	
PWR	1	Gnd	Ground	
	2	V+	12~36V	
(serial comm.)	1	GND	RS485 connector(Optional)	Molex, 5267-03
	2	485+		
	3	485-		
BRK_RES		External regenerative brake resistor connection (used for high inertia brake control)		Molex, 5566-02
CTRL		Input/output control signal line		Molex, 5267-11

■ Internal variable resistance

- Maximum allowed load setting and internal speed setting : CURRENT/SPEED

Set the maximum weight that is being applied to motor. If motor operates for more than 0.1 second at the set weight, then it will stop and show alarm signal. In order to restart the motor, then turn the RST socket on and turn it off. The maximum weight for motor is different for each motor.

Motor allowed output in comparison with load resistance output voltage

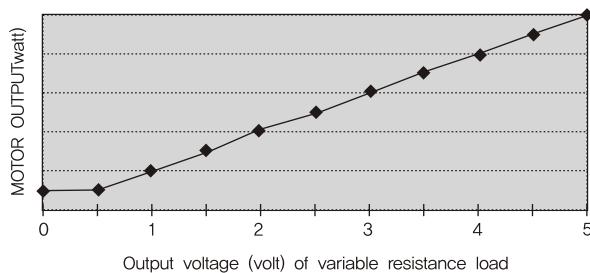

If you set DIP (SW1)' s INT pin at on, then the motor speed is set to internal resistance, V1 (speed). At that time, the internal resistance usage is the same as external resistance usage. From the minimum value to the maximum value, the speed is controlled with parallel to voltage output.

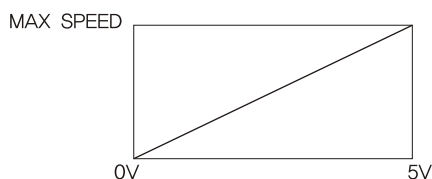

Motor speed vs. external voltage : SPEED_IN

- Deceleration speed setting: S_S(Slow Start)

Determine the acceleration and deceleration sleep of motor. Rapid acceleration and deceleration is possible that is parallel to the voltage output of variable resistance, VR2

If variable resistance is at the min, then it takes motor to reach the maximum speed from the stop about 0.5 seconds. If it is set at the maximum (greater than 90% of maximum, more than 9 measures), then it takes 10 seconds to reach the maximum speed. If rapid acceleration or deceleration is needed, set the S_S resistance at lower than 1 (minimum value).

→ allowed torque of combination type

Unit= N · m

Product name	Deceleration ratio		5	10	15	20	30	50	100	200
	Motor rotation speed	100~2500r/min 3000r/min	20~500	10~250	6,7~167	5~125	3,3~83	2~50	1~25	0,5~12,5
K6LH30N2-A□	100~2500r/minλ		0,54	1,1	1,6	2,2	3,1	5,2	6	6
	3000r/minλ		0,27	0,54	0,81	1,1	1,5	2,6	5,2	6
K8LH50N2-A□	100~2500r/minλ		0,9	1,8	2,7	3,6	5,2	8,6	16	16
	3000r/minλ		0,45	0,9	1,4	1,8	2,6	4,3	8	16
K9LH100N2-A□	100~2500r/minλ		1,8	3,6	5,4	7,2	10,3	17,2	30	30
	3000r/minλ		0,9	1,8	2,7	3,6	5,2	8,6	17,2	30

* In □ of name, it represents a deceleration ratio.

* Rotation direction shows the same ■ color as the motor. In other cases, it's the opposite.

→ Allowed overhang load and allowed thrust

Product name	Deceleration ratio	Allowed overhang load		Allowed thrust load N
		From the front end of shaft : 10mm	From the front end of shaft : 20mm	
K6LH30N2-A□	5	100	150	40
	10, 15, 20	150	200	
	30, 50, 100, 200	200	300	
K8LH50N2-A□	5	200	250	100
	10, 15, 20	300	350	
	30, 50, 100, 200	450	550	
K9LH100N2-A□	5	300	400	150
	10, 15, 20	400	500	
	30, 50, 100, 200	500	650	

* In □ of name, it represents a deceleration ratio.

→ Allowed inertia load MOMENT J of combination type

Unit= $\times 10^{-4}$ kg · m²

Deceleration ratio Product name	5	10	15	20	30	50	100	200
K6LH30N2-A□	1,55	6,2	14	24,8	55,8	155	155	155
K8LH50N2-A□	5,5	22	49,5	88	198	550	550	550
K9LH100N2-A□	25	100	225	400	900	2500	2500	2500

* In □ of name, it represents a deceleration ratio.

→ Rotation speed - torque characteristic

K6LS30N2 / K6LH30N2

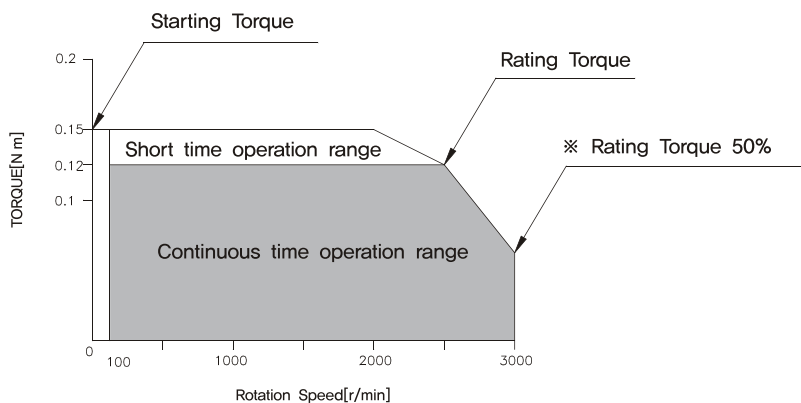

※DC24V is the value without cable extension

K8LS50N2 / K8LH50N2

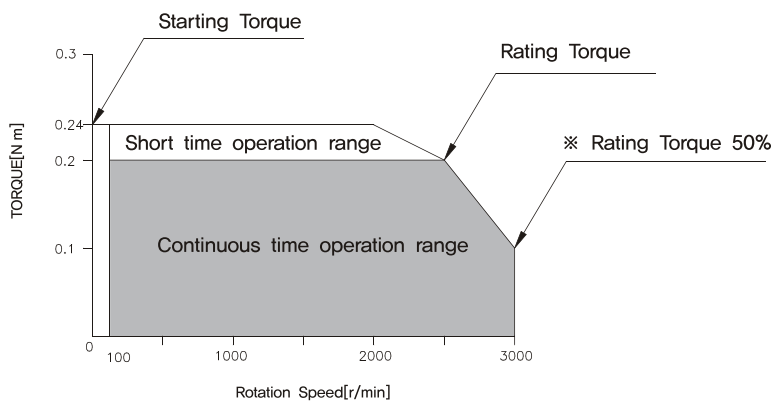

※DC24V is the value without cable extension

K9LS100N2 / K9LH100N2

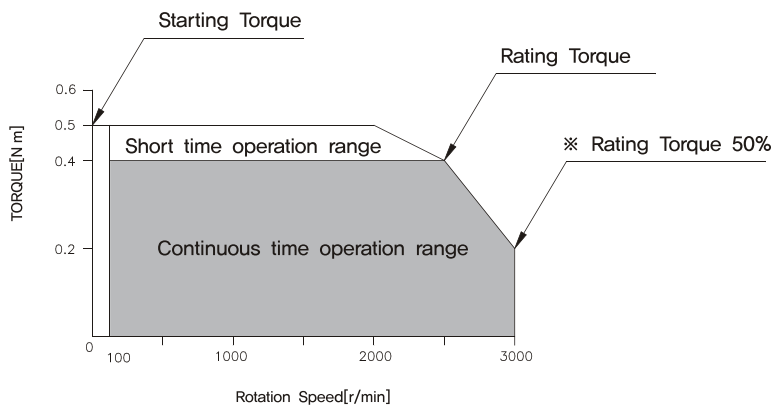

※DC24V is the value without cable extension

→ List of motor/speed control combination

● COMBINATION TYPE · PARALLEL AXIS GEAR HEAD

The names of parts that constitute the unit for motor, gear had and speed control units are as follows.
Motor and parallel axis gear head are already assembled.

Output	Product name	Motor Product name	Gear head product name	Speed control unit
30W	K6LH30N2-A□	K6LH30N2	K6H□B	GUL-2-30
50W	K8LH50N2-A□	K8LH50N2	K8H□B	GUL-2-50
100W	K9LH100N2-A□	K9LH100N2	K9H□B	GUL-2-100

* In □, the number for deceleration ratio should be written.

● STRAIGHT SHAFT TYPE

Output	Product name	Speed control unit
30W	K6LS30N2	GUL-2-30
50W	K8LS50N2	GUL-2-50
100W	K9LS100N2	GUL-2-100

● PINION SHAFT TYPE

Output	Product name	Speed control unit
30W	K6LH30N2	GUL-2-30
50W	K8LH50N2	GUL-2-50
100W	K9LH100N2	GUL-2-100