

BRUSHLESS DC MOTOR UNIT - L Series

100W

□90mm

DC24V INPUT

DIMENSIONS

K9LS100N2

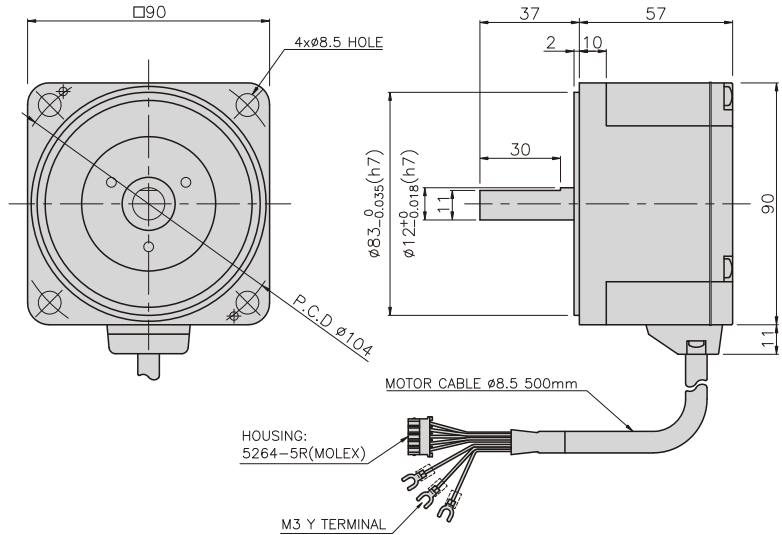

K9LH100N2-A□

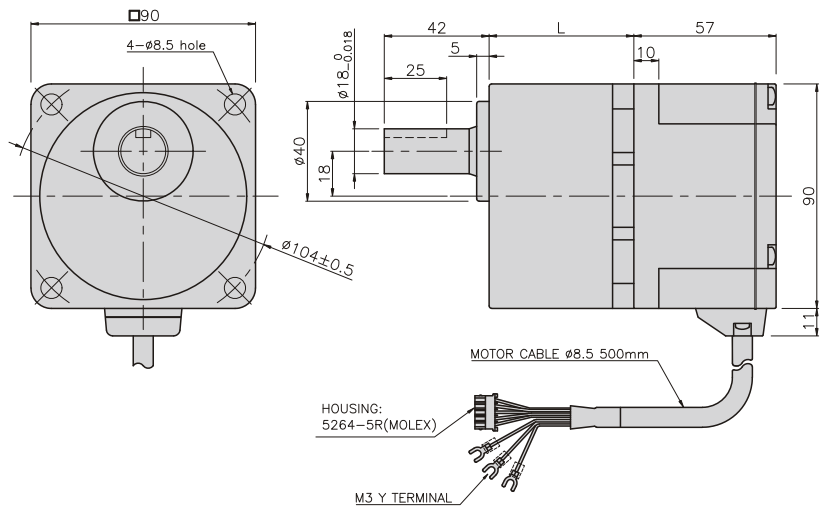

*** KEY · KEY GROOVE**

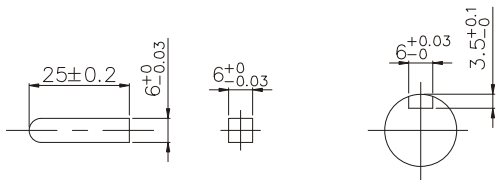

PRODUCT NAME	MOTOR PRODUCT NAME	GEAR HEAD PRODUCT NAME	DECCELERATION RATIO	L	FIXING BOLT
K9LH100N2-A□	K9LH100N2	K9H□B	5~20	45	M8 P1,25×75
			30~100	58	M8 P1,25×90
			200	64	M8 P1,25×95

* In □, the number for deceleration ratio should be written.

* Geared motor is included with fixing bolt set (normal washer, spring washer, cube nut; 4 each)

→ Types

◆ GEARED TYPE/COMBINATION TYPE

TYPE	OUTPUT	PRODUCT NAME	DECELERATION RATIO
COMBINATION TYPE	30W	K6LH30N2-A□	5, 10, 15, 20, 30, 50, 100, 200
	50W	K8LH50N2-A□	5, 10, 15, 20, 30, 50, 100, 200
	100W	K9LH100N2-A□	5, 10, 15, 20, 30, 50, 100, 200

◆ STRAIGHT SHAFT TYPE

OUTPUT	POWER VOLTAGE	PRODUCT NAME
30W	DC24V	K6LS30N2
50W		K8LS50N2
100W		K9LS100N2

◆ PINION SHAFT TYPE

OUTPUT	POWER VOLTAGE	PRODUCT NAME
30W	DC24V	K6LH30N2
50W		K8LH50N2
100W		K9LH100N2

◆ GEAR HEAD

APPLIED MOTOR OUTPUT	GEAR HEAD PRODUCT NAME	DECELERATION RATIO
30W	K6H□B	5, 10, 15, 20, 30, 50, 100, 200
50W	K8H□B	5, 10, 15, 20, 30, 50, 100, 200
100W	K9H□B	5, 10, 15, 20, 30, 50, 100, 200

* In □, the number for deceleration ratio should be written.

→ Specification

Product name	Combination type · parallel axis gear head		K6LH30N2-A□	K8LH50N2-A□	K9LH100N2-A□
	Round shaft type		K6LS30N2	K8LS50N2	K9LS100N
Rating output (continuous)	W		30	50	100
Power input	Rating voltage	V	DC24		
	Rating voltage allowance		±10%		
	Rating input current	A	2,1	3,1	6,0
	Maximum input	A	3,7	5,4	9,8
Rating torque	N · m	0,12	0,2	0,4	
Starting torque	N · m	0,15	0,24	0,5	
Rating rotation speed	r/min	2500			
Speed control range	r/min	100~3000			
Allowed inertia load moment of round shaft type	J×10 ⁻⁴ kg · m ²	1,8	3,3	5,6	
rotor inertia moment	J×10 ⁻⁴ kg · m ²	0,086	0,234	0,611	
Speed change rate	Load	Less than or equal to ±1%: condition 0-rated torque, rated rotation speed, rated voltage, room temperature			
	Voltage	Less than or equal to ±1%: condition rating voltage ±10%, rating rotation speed, no load, room temperature			
	Temperature	Less than or equal to ±1%: condition surrounding temperature 0~+40° C, rating rotation speed, no load, rating voltage			

* The usage duration for starting torque is within 5 seconds at less than 2000r/min

* In □, the number for deceleration ratio should be written.

* Each specification value is the characteristic of motor by itself.

→ Common specifications

Product name	Specification
Rotation speed setting method	Controller panel's speed control volume
Acceleration time/deceleration time	0,5~10 seconds: set at 2500r/min when there is no load (it may change depending on the size of the load) Acceleration time and deceleration control equipment to control at the same time
Input signal	Internal full-up input method, external input voltage read as greater than 2V high (off), same at all input ports
output signal	Open collector output, common for speed out/alarm out, If input voltage from outside is applied to connector #2 PIN, then it comes out through the applied power. Everything else is internal 5V output UI(CTRL)
Protection function	<p>If the following protection mode comes on, control unit alarm signal is shown. Motor stops automatically.</p> <ul style="list-style-type: none"> ● Overload protection mode: If torque that is greater than the rating is applied to the motor for more than 5 seconds ● Overvoltage protection : If voltage applied to the control unit goes over the upper bound of the rating voltage allowance ● Open phase protection : If cable sensor line gets disconnected during motor operation ● Undervoltage protection : If voltage applied to the control unit is less than the lower bound of the rating voltage allowance ● Over speed protection : If motor rotation speed is faster than 2500r/min
Motor insulation class	E TYPE (120° C)
Maximum extension distance	MOTOR – CONTROL UNIT 2m
Rated time	continuous

※ Like weight carried being downwards, L SERIES cannot control motor speed through weight

Motor gets stopped automatically through overvoltage protection if load is being carried downwards or it is heavier than allowed load inertia

→ Normal specifications

Items		Motor	Control unit
Insulation resistance		After being operated continuously at room temperature and humidity, the value measured between coil and case by DC 500V MEGA is greater than or equal to 100MΩ	After being operated continuously at room temperature and humidity, the value measured between heatproof plate and power input is greater than or equal to 100MΩ
Dielectric Strength		After being operated continuously at room temperature and humidity, there shouldn't be any problem between coil and case even when AC 0,5kV is applied for 1 minute.	No problem when 50Hz, AC 0,5kV is applied for one minute No problem when AC 0,5kV is applied for one minute
Used environment	Ambient temperature	0~+50° C(should not freeze)	
	Ambient Humidity	Less than or equal to 85% (not form dews)	
	Altitude	Altitude less than 1000m	
	Ambient environment	Cannot be used under special circumstances such as with corrosive gas, dust, radioactive material, magnetic and vacuum	
	Vibration	Should not apply constant vibration or huge impact According to the JIS C 60068-2-6 sine wave vibration test method Frequency range: 10~55Hz, peak amplitude: 0,15mm sweet direction: 3 directions(X, Y, Z) number of sweeps: 20 times	
Storage environment*2	Ambient temperature	-25~+70° C(should not freeze)	
	Ambient Humidity	Less than or equal to 85% (not form dews)	
	Altitude	Altitude less than 3000m	
Insulation class		UL, CSA STANDARD A TYPE(105° C) EN STANDARD E TYPE(120° C)	—
Protection class		IP65	IP00

- Preservation environment is a short-term value, which includes transportation
- Do not measure insulation resistance and pressure resistance while motor and driver are connected

→ allowed torque of combination type

Unit=N · m(kgf · cm)

Items	Deceleration ratio		5	10	15	20	30	50	100	200
	Speed control range[r/min]		20~500	10~250	6,7~167	5~125	3,3~83	2~50	1~25	0,5~12,5
K6LH30N■-A□	100~2500r/min		0,54(5,4)	1,1(11)	1,6(16)	2,2(22)	3,1(31)	5,2(52)	6(60)	6(60)
	3000r/min		0,27(2,7)	0,54(5,4)	0,81(8,1)	1,1(11)	1,5(15)	2,6(26)	5,2(52)	6(60)
K8LH50N■-A□	100~2500r/min		0,9(9)	1,8(18)	2,7(27)	3,6(36)	5,2(52)	8,6(86)	16(160)	16(160)
	3000r/min		0,45(4,5)	0,9(9)	1,4(14)	1,8(18)	2,6(26)	4,3(43)	8,6(86)	16(160)
K9L100N■-A□	100~2500r/min		1,8(18)	3,6(36)	5,4(54)	7,2(72)	10,3(103)	17,2(172)	30(300)	30(300)
	3000r/min		0,9(9)	1,8(18)	2,7(27)	3,6(36)	5,2(52)	8,6(86)	17,2(172)	30(300)

* Rotation direction shows the same color as the motor. In other cases, it's the opposite.

→ Allowed overhang load and allowed thrust

Product name		Deceleration ratio	Allowed overhang load				Allowed thrust load	
			From the end of output part : 10mm		From the end of output part : 20mm		N	kgf
			N	kgf	N	kgf		
GEARED MOTOR	K6LH30N■-A□	5	100	10	150	15	40	4
		10~20	150	15	200	20		
		30~200	200	20	300	30		
	K8LH50N■-A□	5	200	20	250	25	100	10
		10~20	300	30	350	35		
		30~200	450	45	550	55		
	K9LH100N■-A□	5	300	30	400	40	150	15
		10~20	400	40	500	50		
		30~200	500	50	650	65		
MOTOR	K6LS30N■		70	7	100	10	· Be careful not to weigh thrust. If it's inevitable, keep it under 50% of the motor weight.	
	K8LS50N■		120	12	140	14		
	K9LS100N■		160	16	170	17		

* In dimension, in ■ of name represents power voltage U (single-phase 100-115V) and C (single-phase 200-230V).

* In □ of name, it represents a deceleration ratio.